

Алматы (7273)495-231
Ангарск (3955)60-70-56
Архангельск (8182)63-90-72
Астрахань (8512)99-46-04
Барнаул (3852)73-04-60
Белгород (4722)40-23-64
Благовещенск (4162)22-76-07
Брянск (4832)59-03-52
Владивосток (423)249-28-31
Владикавказ (8672)28-90-48
Владимир (4922)49-43-18
Волгоград (844)278-03-48
Вологда (8172)26-41-59
Воронеж (473)204-51-73
Екатеринбург (343)384-55-89

Иваново (4932)77-34-06
Ижевск (3412)26-03-58
Иркутск (395)279-98-46
Казань (843)206-01-48
Калининград (4012)72-03-81
Калуга (4842)92-23-67
Кемерово (3842)65-04-62
Киров (8332)68-02-04
Коломна (4966)23-41-49
Кострома (4942)77-07-48
Краснодар (861)203-40-90
Красноярск (391)204-63-61
Курск (4712)77-13-04
Курган (3522)50-90-47
Липецк (4742)52-20-81

Магнитогорск (3519)55-03-13
Москва (495)268-04-70
Мурманск (8152)59-64-93
Набережные Челны (8552)20-53-41
Нижегород (831)429-08-12
Новокузнецк (3843)20-46-81
Ноябрьск (3496)41-32-12
Новосибирск (383)227-86-73
Омск (3812)21-46-40
Орел (4862)44-53-42
Оренбург (3532)37-68-04
Пенза (8412)22-31-16
Петрозаводск (8142)55-98-37
Пермь (342)205-81-47

Ростов-на-Дону (863)308-18-15
Рязань (4912)46-61-64
Самара (846)206-03-16
Санкт-Петербург (812)309-46-40
Саратов (845)249-38-78
Севастополь (8692)22-31-93
Саранск (8342)22-96-24
Симферополь (3652)67-13-56
Смоленск (4812)29-41-54
Сочи (862)225-72-31
Ставрополь (8652)20-65-13
Сургут (3462)77-98-35
Сыктывкар (8212)25-95-17
Тамбов (4752)50-40-97
Тверь (4822)63-31-35

Тольятти (8482)63-91-07
Томск (3822)98-41-53
Тула (4872)33-79-87
Тюмень (3452)66-21-18
Ульяновск (8422)24-23-59
Улан-Удэ (3012)59-97-51
Уфа (347)229-48-12
Хабаровск (4212)92-98-04
Чебоксары (8352)28-53-07
Челябинск (351)202-03-61
Череповец (8202)49-02-64
Чита (3022)38-34-83
Якутск (4112)23-90-97
Ярославль (4852)69-52-93

Россия +7(495)268-04-70

Казахстан +7(7172)727-132

Киргизия +996(312)96-26-47

<https://microsensor.nt-rt.ru/> || moj@nt-rt.ru

Датчик давления МРМ4841. Технические характеристики.



Introduction

Applications

- Machine manufacturing
- Petrochemical engineering
- Measurement and control
- Hydraulic and pneumatic
- Energy and water treatment

Brief Introduction

MPM4841 pressure transmitter uses a high-stability, high reliability piezoresistive pressure sensing element and a special conditioning circuit to output a standard current or voltage signal. It is compact in size, excellent in quality, stable and reliable in overall performance. It is very suitable for general industry and cost effective.

We can also provide products that meet the requirements of our customers for their specified applications in a short period of time.

Pressure Type

Gauge / Absolute / Sealed Gauge

Pressure Range

Type A: 0bar~0.35bar...200bar

Type B: 0bar~250bar...600bar

Output Signal

4mA~20mA DC

0V~10V DC

0.5V~4.5V DC

0V~5V DC

1V~5V DC

Reference Accuracy

Max. $\pm 0.5\%$ FS, see details on specifications

Media

Liquids compatible with wetted material

Certificates

Specifications

Pressure Ranges and Limits

Type	Range bar	Max. overpressure bar	Min. burst pressure bar	Pressure Type
A	0~0.35	1	5	G
	0~0.6	1.8	5	G
	0~1	3	5	G.A
	0~1.6	3	5	G.A
	0~2.5	5	10	G.A
	0~4	8	12	G.A
	0~6	12	20	G.A
	0~10	20	30	G.A
	0~16	30	60	G.A
	0~25	50	75	G.A
	0~40	80	120	S.A
	0~60	120	180	S.A
	0~100	200	300	S.A
	0~160	300	400	S.A
	0~200	300	400	S.A
B	0~250	400	500	S.A
	0~400	600	800	S.A
	0~500	750	1000	S.A
	0~600	750	1000	S.A

The above measurement range is also available in units of kg/cm², MPa and kPa etc.

See the pressure unit conversion table for details.

Overpressure: products performance is not affected within the nominal max. overload pressure range.

Burst Pressure: Damage the products beyond the nominal min. pressure range.

Pressure Type: G: gauge, A: absolute, S: sealed gauge

Pressure Unit Conversion Table

Unit	Pa(N/m ²)	kPa	MPa	bar	mbar
1 Pa(N/m ²)	1	0.001	0.000001	0.00001	0.01
1 kPa	1000	1	0.001	0.01	10
1 MPa	1000000	1000	1	10	10000
1 bar	100000	100	0.1	1	1000
1 mbar	100	0.1	0.0001	0.001	1
1 mmH ₂ O	9.807	0.009807	0.000009807	0.00009807	0.09807
1 kg/cm ²	98070	98.07	0.0981	0.9807	980.7
1 atm	101300	101.3	0.1013	1.013	1013
1 mm Hg	133.3	0.1333	0.0001333	0.001333	1.333
1 psi	6895	6.895	0.006895	0.0689	68.948
Unit	mmH ₂ O	kg/cm ²	atm	mm Hg	psi
1 Pa(N/m ²)	0.102	0.0000102	0.000009869	0.007501	0.000145
1 kPa	101.9716	0.0102	0.009869	7.501	0.145
1 MPa	101972	10.2	9.869	7501	145.038
1 bar	10197	1.02	0.9869	750.1	14.5038
1 mbar	10.1972	0.00102	0.0009869	0.7501	0.0145
1 mmH ₂ O	1	0.0001	0.00009678	0.0734	0.001422
1 kg/cm ²	10000	1	0.9678	734.2	14.224
1 atm	10330	1.033	1	760.1	14.68
1 mm Hg	13.62	0.001362	0.001316	1	0.0193
1 psi	704.3	0.0703	0.068	51.71	1

Performance test standards and baseline test conditions

Test standard: IEC 61298-1

Reference Condition

Temperature: 15°C ~25°C

Atmospheric Pressure: 860mbar~1,060mbar

Humidity: 45% ~75 % RH

Power Supply: 24 V DC

Performance

Accuracy: $\pm 0.5\%$ FS

Long-term Stability: $\pm 0.3\%$ FS/ year (Max.)

Based on standard and baseline test conditions, including linearity, hysteresis and repeatability.

Ambient Temperature Effect

Zero Temperature Coefficient:

$\pm 0.05\%$ FS/°C (≤ 1 bar)

$\pm 0.02\%$ FS/°C (> 1 bar)

FS Temperature Coefficient:

$\pm 0.05\%$ FS/°C (≤ 1 bar)

$\pm 0.02\%$ FS/°C (> 1 bar)

Power Supply Impact

Zero and FS changes do not exceed $\pm 0.005\%$ FS/V

Load Impact

Zero and FS changes do not exceed $\pm 0.05\%$ FS/k Ω

Weight

A: ≤ 150 g

B: ≤ 200 g

Vibration Environment

Vibration resistance: 10g(@20Hz~2000Hz) (IEC 60068-2-6 standard, under resonance conditions), available for vibration resistance up to 20g according to customer's requirements.

Impact resistance: 100g/11ms (IEC 60068-2-27 standard, mechanical shock)

Output Signal

Wires	Output	Power Supply
2 wire	4mA~20mA DC	8~30V DC
3 wire	0V~10V DC	12~30V DC
3 wire	0.5V~4.5V DC	12~30V DC
3 wire	0V~5V DC	12~30V DC
3 wire	1V~5V DC	12~30V DC

Service Life

Max. load cycle: 10^7 times

Insulation Resistance

$\geq 100M\Omega@, 500V$ DC

Time Performance

Range	Response Time	Power-on Time
≥ 350 mbar	< 3ms	< 20ms

Environmental Conditions

Item	Operation Condition
Medium Temperature	-10°C ~80°C
Ambient Temperature	-10°C ~80°C
Storage Temperature	-40°C ~70°C
Protection	IP65

Technical Parameter

Output	4mA~20mA DC	0.5V~4.5V DC	1V~5V DC	0V~5V DC	0V~10V DC
Power Supply	8V~30V DC	12V~30V DC			
Power Consumption Current	≤22mA	≤7mA			
Load Resistance	≤ (U-8) /0.02 (Ω)	≥10kΩ			
Transmission Distance	< 1000m(@24V DC, load 250Ω)	< 5 m(@24V DC, load 10kΩ)			

Electromagnetic Compatibility

No.	Item	Standard	Testing Conditions	Performance
1	Radiation Interference (housing)	GB/T 9254/EN 55011	30MHz~1000MHz	OK
2	Conducted Interference (DC)	GB/T 9254/EN 55011	0.15MHz~30MHz	OK
3	Electrostatic Discharge Immunity	GB/T 17626.2/IEC 61000-4-2	4kV(contact), 8kV(air)	A(*1)
4	Radio Frequency Magnetic Field	GB/T 17626.3/IEC 61000-4-3	10V/m(80MHz~1GHz)	A(*1)
5	Power Frequency Magnetic Field	GB/T 17626.8/IEC 61000-4-8	30A/m	A(*1)
6	Electrical Fast Burst Immunity	GB/T 17626.4/IEC 61000-4-4	2kV(5/50ns,100kHz)	A(*1)
7	Surge Immunity	GB/T 17626.5/IEC 61000-4-5	500V(12μs/50μs)	B(*2)
8	RF Induction Conduction Anti-harassment	GB/T 17626.6/IEC 61000-4-6	10V(150kHz~80MHz)	A(*1)

*1: Performance class A, normal performance within the limits of the specifications

*2: Performance class B, performance or function is temporarily reduced or lost, but can recover; keeps the actual operating conditions, storage and data unchanged.

Construction Material

A: Welded

Housing: SS 316L

Sensor Housing: SS 304/SS 316L

Plug: PA

Diaphragm: SS 316L

Rectangle Sealing Ring: Viton

B: Assembled

Housing: SS 316L

O-ring: Viton

Sensor Housing:SS 316L

Plug: PA

Diaphragm: SS 316L

Rectangle Sealing Ring: Viton

Order Guide

Electrical Connection Code

Code	Detail	Standard
B	4 -pin plug	DIN 175301-803 A plug

Electrical Connection (Unit: mm)

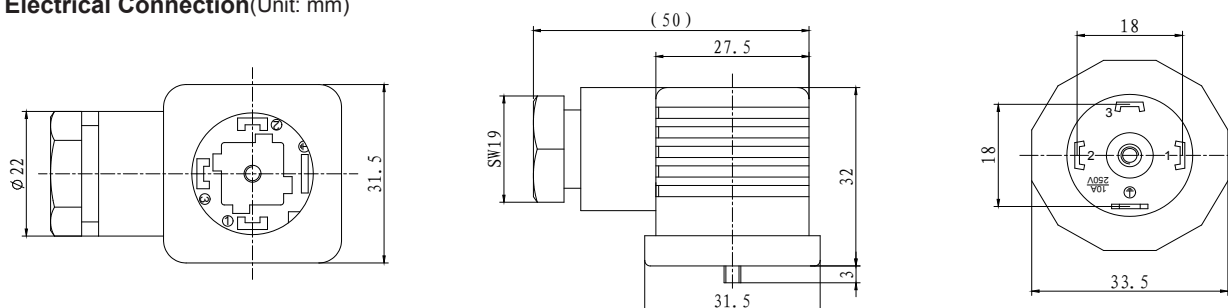

DIN 175301-803 A plug

Applicable cable: 5-core with shielded sleeve OD: \varnothing 4.9 mm

Pin	2-wire	3-wire
1	(+V)	(+V)
2	(0V/+OUT)	(GND)
3	Null	(+OUT)

Output

Code	Output Signal
E	4mA~20mA DC
K	0.5V~4.5V DC
V	0V~10V DC
J	0V~5V DC
F	1V~5V DC

Construction Material

Code	Construction Material		
	Diaphragm	Process Connection	Housing
24	SS 316L	SS 316L	SS 316L

Schematic Diagram of Parts Contacting with the Medium

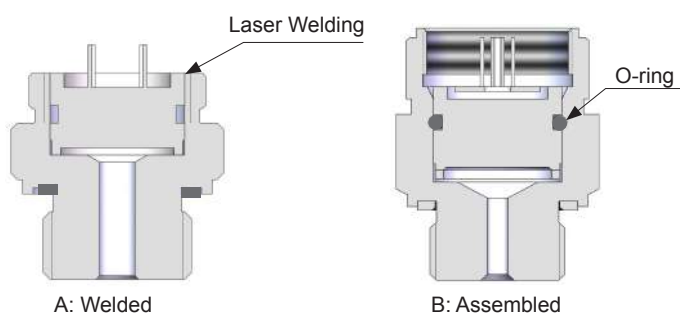

Process Connection Code

Code	Process Connection	Standard
L01	G1/8 B male(≤400bar)	EN 837
L02	G1/4 B male	EN 837
L03	G3/8 B male	EN 837
L04	G1/2 B male	EN 837
L05	G1/8 female(≤400bar)	EN 837
L06	G1/4 female	EN 837
L07	G1/4 A male	ISO 1179-2
L08	G3/8 A male	ISO 1179-2
L09	G1/2 A male	ISO 1179-2
L10	G1/4 female	ISO 1179-1
L11	M12X1.5 male	ISO 9974-2
L12	M14X1.5 male	ISO 9974-2
L13	M20X1.5 male	ISO 9974-2
L14	M20X1.5 male	EN 837
L15	NPT1/8 male(≤400bar)	ANSI/ASME B1.20.1
L16	NPT1/4 male	ANSI/ASME B1.20.1
L17	NPT1/2 male	ANSI/ASME B1.20.1
L18	NPT1/8 female(≤400bar)	ANSI/ASME B1.20.1
L19	NPT1/4 female	ANSI/ASME B1.20.1
L20	NPT1/2 female	ANSI/ASME B1.20.1
L21	R1/4 male	ISO 7
L22	R3/8 male	ISO 7
L23	R1/2 male	ISO 7
L24	7/16-20UNF male	SAE J514 E

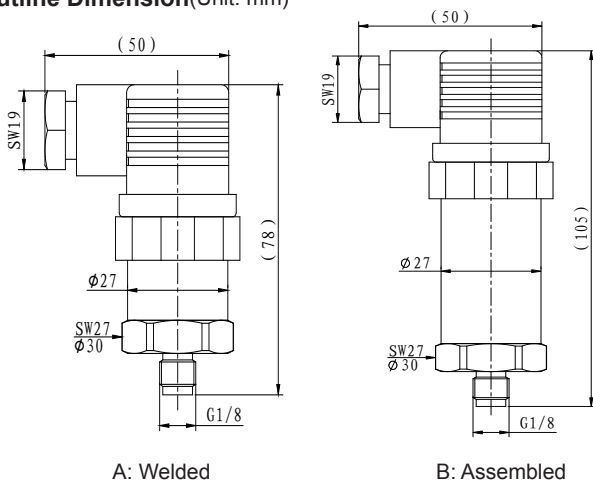
Dimension Diagram
Outline Dimension(Unit: mm)

Process Connection Dimension (Unit: mm)

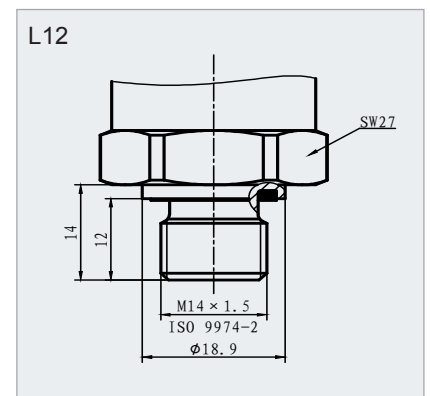
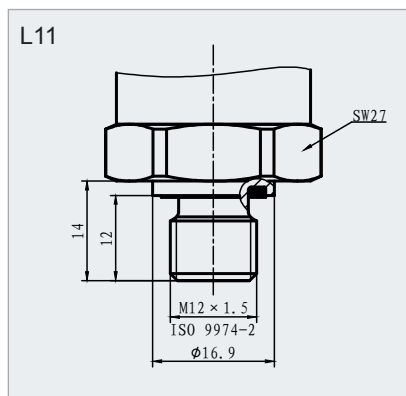
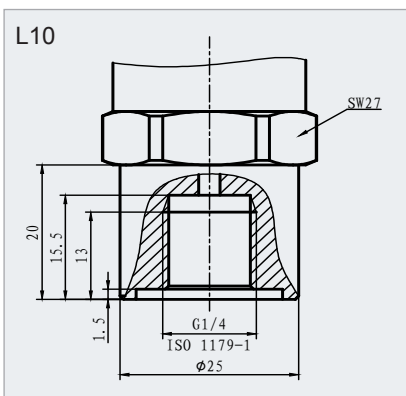
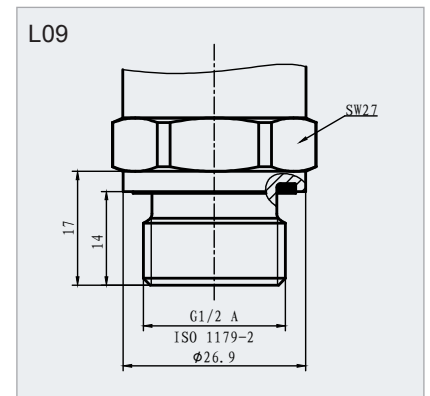
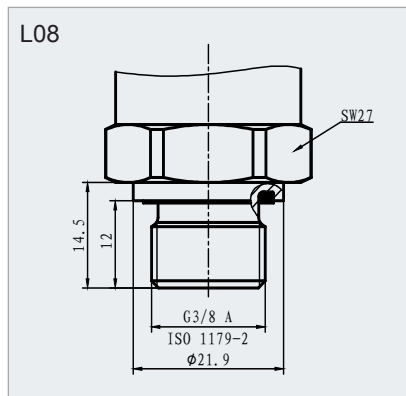
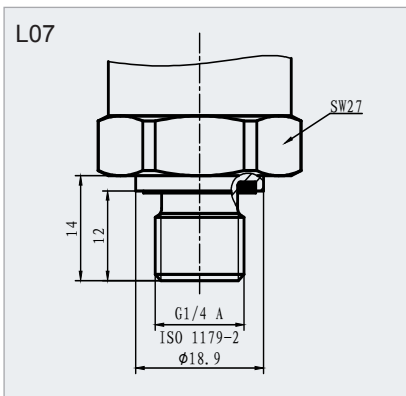
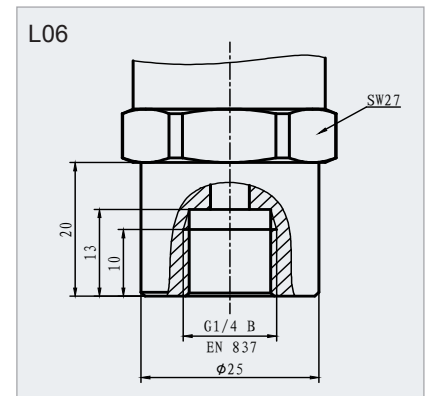
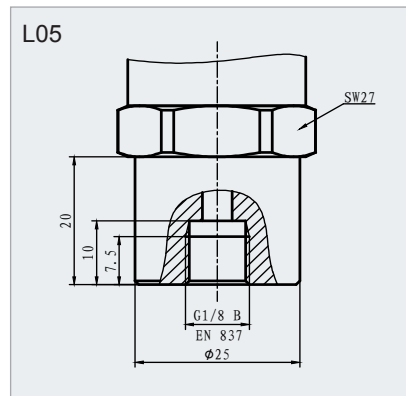
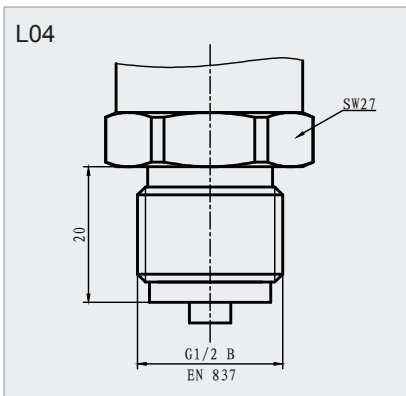
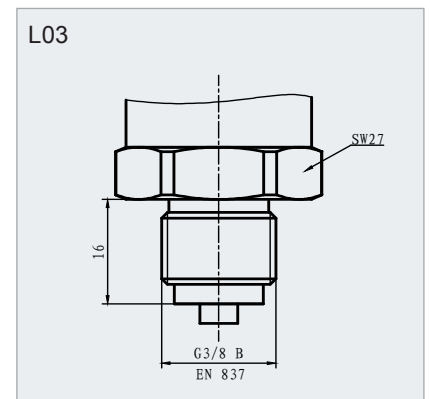
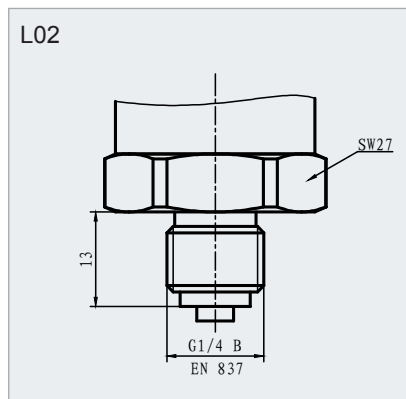
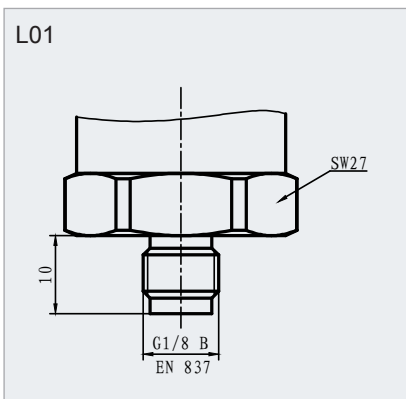

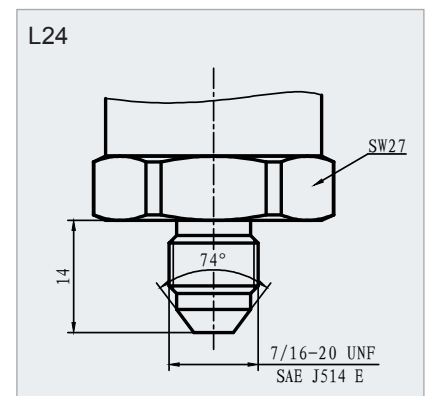
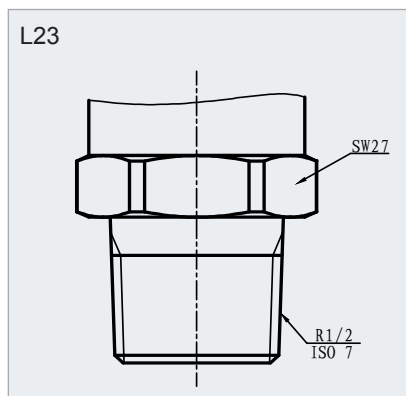
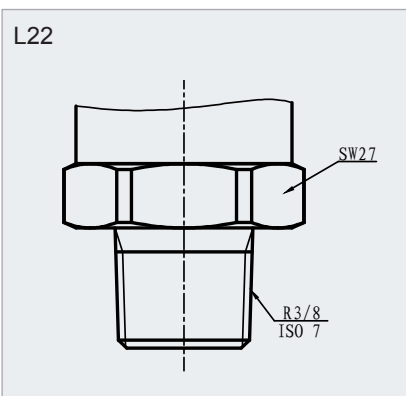
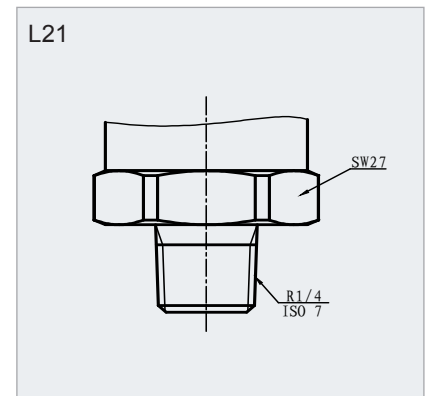
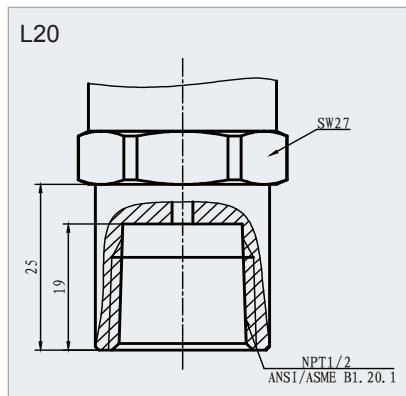
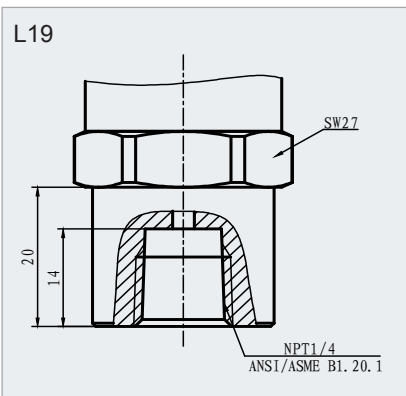
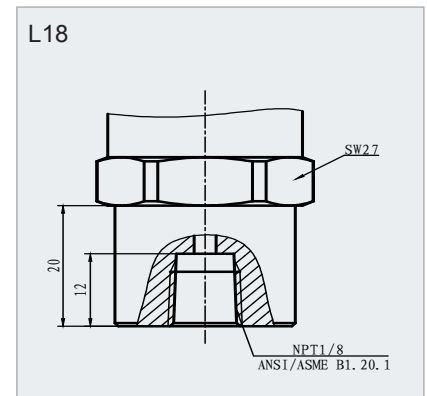
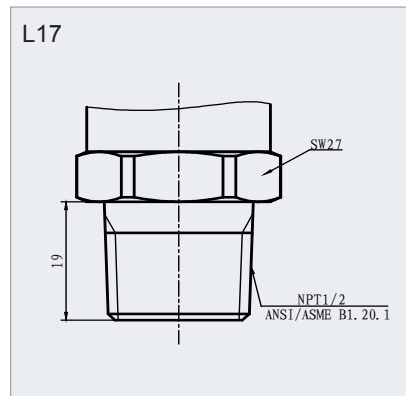
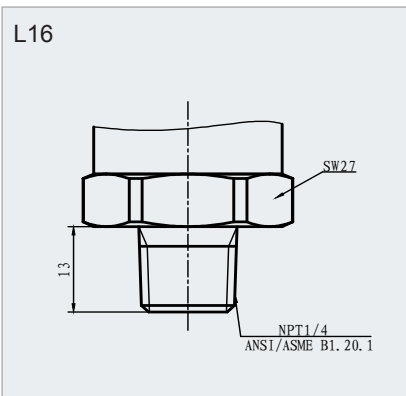
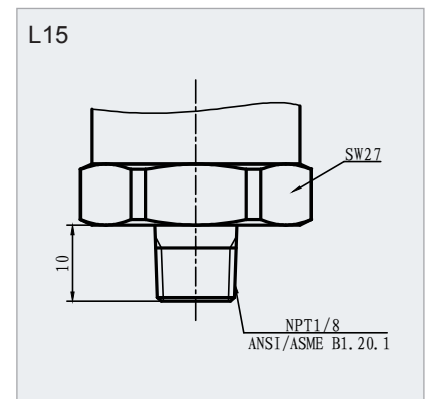
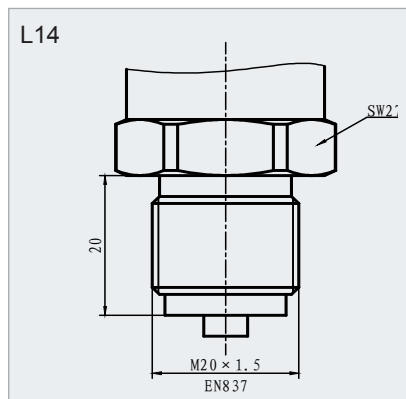
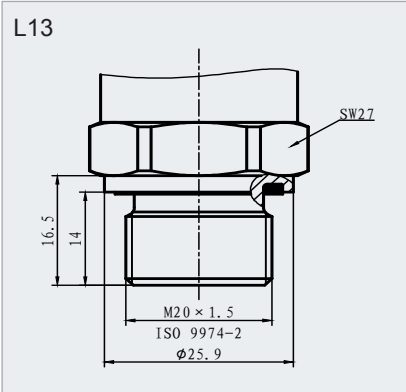

Disclaimer

All data is for products description only and is not legally efficient.

Details may be subject to change due to further improvements.

Name and content of hazardous substances in the product

Component Name	Hazardous substances					
	Pb	Hg	Cd	Cr(VI)	PBB	PBDE
Sensing Element	×	○	○	○	○	○
Circuit	×	○	○	○	○	○
Housing	○	○	○	○	○	○
Plug	×	○	○	○	○	○

The above form is made in accordance with the provision of SJ/T 11364

○: Indicates that the content of the hazardous substance in all homogeneous materials of the part is below the limit requirement specified in GB/T 26572. It meets the environmental requirements of the EU RoHS Directive
 ×: Indicates that the harmful substance is at least in a certain homogeneous material of the part exceeding the limit requirement of GB/T 26572. It meets the environmental requirements of the EU RoHS Directive.



The number in the logo indicates the environmentally friendly service life is 10 years under normal use.



Some components may also have an environmentally friendly life mark, and their protection life is based on the number in the logo.

Legal Notice

Copyright © Micro Sensor Co., Ltd. 2019

All rights reserved.

The content of this manual must not be duplicated, processed, reproduced, modified or made available to third party in any form whatsoever without the written consent of Micro Sensor Co., Ltd.

Алматы (7273)495-231
Ангарск (3955)60-70-56
Архангельск (8182)63-90-72
Астрахань (8512)99-46-04
Барнаул (3852)73-04-60
Белгород (4722)40-23-64
Благовещенск (4162)22-76-07
Брянск (4832)59-03-52
Владивосток (423)249-28-31
Владикавказ (8672)28-90-48
Владимир (4922)49-43-18
Волгоград (844)278-03-48
Вологда (8172)26-41-59
Воронеж (473)204-51-73
Екатеринбург (343)384-55-89

Иваново (4932)77-34-06
Ижевск (3412)26-03-58
Иркутск (395)279-98-46
Казань (843)206-01-48
Калининград (4012)72-03-81
Калуга (4842)92-23-67
Кемерово (3842)65-04-62
Киров (8332)68-02-04
Коломна (4966)23-41-49
Кострома (4942)77-07-48
Краснодар (861)203-40-90
Красноярск (391)204-63-61
Курск (4712)77-13-04
Курган (3522)50-90-47
Липецк (4742)52-20-81

Магнитогорск (3519)55-03-13
Москва (495)268-04-70
Мурманск (8152)59-64-93
Набережные Челны (8552)20-53-41
Нижегород (831)429-08-12
Новокузнецк (3843)20-46-81
Новосибирск (383)227-86-73
Омск (3812)21-46-40
Орел (4862)44-53-42
Оренбург (3532)37-68-04
Пенза (8412)22-31-16
Петрозаводск (8142)55-98-37
Псков (8112)59-10-37
Пермь (342)205-81-47

Ростов-на-Дону (863)308-18-15
Рязань (4912)46-61-64
Самара (846)206-03-16
Санкт-Петербург (812)309-46-40
Саратов (845)249-38-78
Севастополь (8692)22-31-93
Саранск (8342)22-96-24
Симферополь (3652)67-13-56
Смоленск (4812)29-41-54
Сочи (862)225-72-31
Ставрополь (8652)20-65-13
Сургут (3462)77-98-35
Сыктывкар (8212)25-95-17
Тамбов (4752)50-40-97
Тверь (4822)63-31-35

Тольятти (8482)63-91-07
Томск (3822)98-41-53
Тула (4872)33-79-87
Тюмень (3452)66-21-18
Ульяновск (8422)24-23-59
Улан-Удэ (3012)59-97-51
Уфа (347)229-48-12
Хабаровск (4212)92-98-04
Чебоксары (8352)28-53-07
Челябинск (351)202-03-61
Череповец (8202)49-02-64
Чита (3022)38-34-83
Якутск (4112)23-90-97
Ярославль (4852)69-52-93

Россия +7(495)268-04-70

Казахстан +7(7172)727-132

Киргизия +996(312)96-26-47