

Преобразователь частоты серии P1500-W для насоса постоянного давления

Технические характеристики

По вопросам продаж и поддержки обращайтесь:

Алматы (7273)495-231	Калининград (4012)72-03-81	Омск (3812)21-46-40	Сыктывкар (8212)25-95-17
Ангарск (3955)60-70-56	Калуга (4842)92-23-67	Орел (4862)44-53-42	Тамбов (4752)50-40-97
Архангельск (8182)63-90-72	Кемерово (3842)65-04-62	Оренбург (3532)37-68-04	Тверь (4822)63-31-35
Астрахань (8512)99-46-04	Киров (8332)68-02-04	Пенза (8412)22-31-16	Тольятти (8482)63-91-07
Барнаул (3852)73-04-60	Коломна (4966)23-41-49	Петрозаводск (8142)55-98-37	Томск (3822)98-41-53
Белгород (4722)40-23-64	Кострома (4942)77-07-48	Псков (8112)59-10-37	Тула (4872)33-79-87
Благовещенск (4162)22-76-07	Краснодар (861)203-40-90	Пермь (342)205-81-47	Тюмень (3452)66-21-18
Брянск (4832)59-03-52	Красноярск (391)204-63-61	Ростов-на-Дону (863)308-18-15	Ульяновск (8422)24-23-59
Владивосток (423)249-28-31	Курск (4712)77-13-04	Рязань (4912)46-61-64	Улан-Удэ (3012)59-97-51
Владикавказ (8672)28-90-48	Курган (3522)50-90-47	Самара (846)206-03-16	Уфа (347)229-48-12
Владимир (4922)49-43-18	Липецк (4742)52-20-81	Саранск (8342)22-96-24	Хабаровск (4212)92-98-04
Волгоград (844)278-03-48	Магнитогорск (3519)55-03-13	Санкт-Петербург (812)309-46-40	Чебоксары (8352)28-53-07
Вологда (8172)26-41-59	Москва (495)268-04-70	Саратов (845)249-38-78	Челябинск (351)202-03-61
Воронеж (473)204-51-73	Мурманск (8152)59-64-93	Севастополь (8692)22-31-93	Череповец (8202)49-02-64
Екатеринбург (343)384-55-89	Набережные Челны (8552)20-53-41	Симферополь (3652)67-13-56	Чита (3022)38-34-83
Иваново (4932)77-34-06	Нижний Новгород (831)429-08-12	Смоленск (4812)29-41-54	Якутск (4112)23-90-97
Ижевск (3412)26-03-58	Новокузнецк (3843)20-46-81	Сочи (862)225-72-31	Ярославль (4852)69-52-93
Иркутск (395)279-98-46	Ноябрьск (3496)41-32-12	Ставрополь (8652)20-65-13	
Казань (843)206-01-48	Новосибирск (383)227-86-73	Сургут (3462)77-98-35	
Россия +7(495)268-04-70	Киргизия +996(312)-96-26-47	Казахстан +7(7172)727-132	

PI500-W Series

Constant Pressure Water Pump Inverter Operating manual



Foreword

Thank you for choosing POWTRAN PI500-W series frequency inverter special for constant pressure water supply. This product made by POWTRAN is based on years of experience in professional production and sale, and designed for Water supply occasion.

For any problem when using this product, please contact your local authorized dealer or directly contact with POWTRAN, our professionals will happy to serve you.

The end-users should hold this manual, and keep it well for future maintenance & care, and other application occasions. For any problem within the warranty period, please fill out the warranty card and fax it to the our authorized dealer.

The contents of this manual are subject to change without prior notice. To obtain the latest information, please visit our website.

Modified record

Serial No.	Modified date	Modified content record	Modified version
1	2022.06	Added chapter 4-3-3	V1.1
2	2023.03	1、Modifying Terminal Callout Drawings 2、Adjust some parameters 3、Add 4 DI terminals	V2.0
3			

Contents

Chapter 1	Inspection and safety precautions	1
1-1.	Inspection after unpacking	1
1-1-1.	Instructions on nameplate	1
1-1-2.	Model designation	1
1-2.	Safety precautions	2
1-3.	Precautions	4
1-4.	Scope of applications	6
Chapter 2	Standard specifications	7
2-1.	Technical specifications	7
2-2.	Standard specifications	10
Chapter 3	Keyboard	14
3-1.	Keyboard description	14
3-2.	Keyboard indicators	14
3-3.	Description of operation panel keys	15
3-4.	Keyboard display letters and numbers correspondence table	15
3-5.	Example of parameter settings	16
3-5-1.	Instructions on viewing and modifying function code	16
3-5-2.	The way to read parameters in various status	17
3-5-3.	Password settings	17
3-5-4.	Motor parameter auto tuning	17
Chapter 4	Installation and commissioning	18
4-1.	Installation direction and space	18
4-2.	Wiring Diagram	20
4-2-1.	Wiring diagram	20
4-3.	Main circuit terminal	21
4-3-1.	Main circuit terminal arrangement	21
4-3-2.	Function description of main circuit terminal	24
4-3-3.	Varistor and safety capacitor switch	25
4-4.	Control circuit terminals	26
4-4-1.	Control circuit terminals arrangement	26
4-4-2.	Description of control circuit terminals	26
4-5.	Wiring Precautions	28
Chapter 5	Function parameter	30
5-1.	Menu grouping	30
5-1-1.	d0group - Monitoring function group	31
5-1-2.	F0 group - Basic function group	33
5-1-3.	F1 group - Input terminal	35
5-1-4.	F2 group - Output terminals group	38
5-1-5.	F3 group - Startand stopcontrolgroup	40
5-1-6.	F4 group - V/Fcontrolparameters	41
5-1-7.	F5 group - Vector control parameters	43
5-1-8.	F6 group - Keyboardanddisplay	43
5-1-9.	F7 group - Auxiliaryfunction group	45
5-1-10.	F8 group - Fault and protection	46
5-1-11.	F9group - Communication parameter	47
5-1-12.	Fb group - Controloptimization parameters	47
5-1-13.	E2 group - PID function	47

5-1-14. E3 group - Virtual DI.Virtual DO	48
5-1-15. E8 group - Constant pressure water supply special group	49
5-1-16. b0 group - Motor parameters	53
5-1-17. y0 group - Function code management	54
5-1-18. y1 group - Fault inquiry	56
Chapter 6 Troubleshooting	58
6-1. Fault alarm and countermeasures	58
6-2. EMC (Electromagnetic compatibility)	62
6-2-1. Definition	62
6-2-2. EMC standard	62
6-3. EMC directive	62
6-3-1. Harmonic effect	62
6-3-2. Electromagnetic interference and installation precautions	62
6-3-3. Remedies for the interference from the surrounding electromagnetic equipment to the inverter	63
6-3-4. Remedies for the interference from the inverter to the surrounding electromagnetic equipment	63
6-3-5. Remedies for leakage current	63
6-3-6. Precautions on installing EMC input filter at the input end of power supply	64
Chapter 7 Dimension	65
7-1. Dimension	65
7-1-1. Product outside drawing, installation size upper cover plate	65
7-1-2. PI500-W series	65
7-1-3. PI500-W series(With DC reactor and base)	72
7-1-4. Iron shell floor mounted series	73
7-1-5. Keyboard Size Diagram	74
Chapter 8 Maintenance and repair	76
8-1. Maintenance and repair	76
8-2. Parts for regular replacement	76
8-3. Storage	77
8-4. Capacitor	77
8-4-1. Capacitor rebuilt	77
8-5. Measuring and readings	78
Chapter 9 Optional part	79
Chapter 10 Warranty	81
Appendix I RS485 Communication protocol	82
Appendix II Application cases of constant pressure water supply	90

Chapter 1 Inspection and safety precautions

POWTRAN frequency inverters have been tested and inspected before leaving factory. After purchasing, please check if its package is damaged due to careless transportation, and if the specifications and model of the product are consistent with your order requirements. For any problem, please contact your local authorized POWTRAN dealer or directly contact this company.

1-1. Inspection after unpacking

- ※ Check if that packing container contains this unit, one manual and one warranty card.
- ※ Check the nameplate on the side of the frequency inverter to ensure that the product you have received is right the one you ordered.

1-1-1. Instructions on nameplate

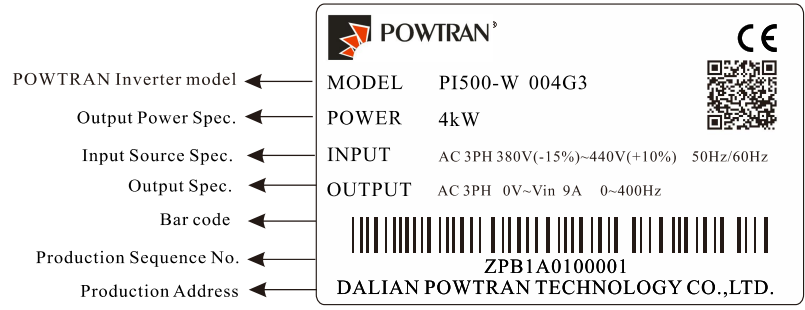

Figure 1-1: Nameplate description

1-1-2. Model designation

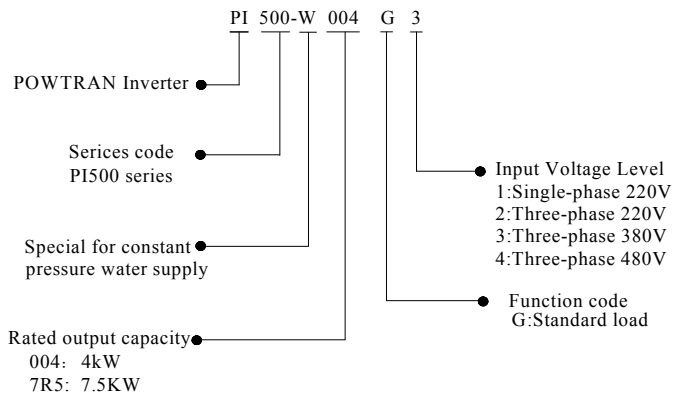









Figure 1-2: Model description





1-2.Safety precautions

Safety precautions in this manual are divided into the following two categories:

 **Danger:** The dangers caused by failure to perform required operation, may result in serious injury or even death;

 **Caution:**The dangers caused by failure to perform required operation, may result in moderate injury or minor injury, and equipment damage;

Process	Type	Explanation
Before installation	 Danger	<ul style="list-style-type: none"> ●When unpacking, if control system with water, parts missed or component damaged are found, do not install. ●If packing list does not match the real name, do not install.
	 Note	<ul style="list-style-type: none"> ●When carrying the inverter, be sure to hold on the housing. If grab the front cover, the main body of inverter may fall down and there is the risk of damage to the equipment. ●Gently carry with care, otherwise there is the risk of damage to equipment. ●Do not use the frequency inverter with damage or missing parts,otherwise there is the risk of injury. ●This device has passed the withstand voltage test before leaving factory,do not test any parts of the inverter .High voltage may lead to damage to the inverter insulation and internal parts.
When installing	 Danger	<ul style="list-style-type: none"> ●Do not modify the inverter .The modified inverter may has risk of electric shock .We shall not take any responsibility if your company or your customer has modified the product. ●Never twist the mounting bolts of the equipment components,especially the bolt with the red mark.
	 Note	<ul style="list-style-type: none"> ●Non-electrical construction professionals are not allowed to install,maintain, inspect or replace parts.Otherwise there is a risk of electric shock. ●Encoder must use the shielded wire, and the shielding layer must ensure the single-ended grounded. ●Do not install transformers or other devices that generate electromagnetic waves or interference around the inverter, otherwise it will lead to the wrong operation of the inverter . if need to install such kind of device , a shield plate shall be set between the device and the inverter .
When wiring	 Danger	<ul style="list-style-type: none"> ●Do not connect the wire when power on , otherwise there is a risk of electric shock. Please cut off the power of all equipment before checking. Even though the power is cut off , there is residual voltage in the internal capacitor. Please wait at least 10 minutes after power off. ●The contact current of inverter over than 3.5mA, please ensure the grounding of inverter is good . Otherwise there is a risk of electric shock.
	 Note	<ul style="list-style-type: none"> ●Please connect the output terminal U,V,W of inverter to the input terminal U,V,W of motor. Be sure the motor terminals and inverter terminals are in same phase sequence. If the phase sequence is different , it will cause the motor to rotate in reverse. ●Do not connect the power to the output terminal of inverter, otherwise it will damage the inverter , even cause fire. ●In some systems , the machine may start suddenly when power

Process	Type	Explanation
		<p>on, there is a risk of death or injury.</p> <ul style="list-style-type: none"> ●Before switching on the inverter power , please make sure the cover plate of inverter is firmly installed , and the motor is allowed to restart . Make sure the rated voltage of inverter is consistent with the power supply voltage. ●If the main circuit power voltage is used incorrectly, there will be a danger of fire. ●Do not connect the input power source to the output terminals (U,V,W) of inverter . Otherwise there is a risk of damage to inverter.
After energizing	 Danger	<ul style="list-style-type: none"> ●Do not open cover plate after energizing. Otherwise there is a risk of electric shock. ●Do not touch any input and output terminals of the inverter. Otherwise there is a risk of electric shock. ●Do not remove the cover of inverter or touch the printed circuit board when it is power on , otherwise there is a risk of electric shock!
	 Note	<ul style="list-style-type: none"> ●Please do not change the inverter manufacturer parameters.Otherwise it may cause damage to this unit. ●If you need to identify the parameters, please pay attention to the danger of injury during motor rotation. Otherwise it may cause an accident.
During operation	 Danger	<ul style="list-style-type: none"> ●Do not touch the cooling fan and the discharge resistor to feel the temperature. Otherwise it may cause burns. ●Non-professional personnel is not allowed to detect signal when operating. Doing so may cause personal injury or damage to this unit!
	 Note	<ul style="list-style-type: none"> ●When the inverter is operating, you should avoid that objects fall into this unit.Otherwise cause damage to this unit. ●Do not start/stop the driver by switching on/off contactor.Otherwise cause damage to this unit.
When maintaining	 Danger	<ul style="list-style-type: none"> ●Do not perform repairs and maintenance for the live electrical equipment. Otherwise there is a risk of electric shock. ●The repairs and maintenance task can be performed only when the inverter bus voltage is lower than 36V,Otherwise, the residual charge from capacitor would cause personal injury. ●Non-well-trained professional personnel is not allowed toperform repairs and maintenance of inverter. Doing this may cause personal injury or damage to this unit. ●After replacing the inverter, parameter settings must be redone, all pluggable plugs can be operated only in the case of powering off. ●Do not power on and operate the damaged inverter, otherwise it will enlarge the damage.

1-3.Precautions

No.	Type	Explanation
1	Motor insulation inspection	Please perform motor insulation inspection for the first time use, re-use after leaving unused for a long time as well as regular check, in order to prevent damage to the inverter because of the motor's winding insulation failure. Wiring between motor and inverter shall be disconnected, it is recommended that the 500V voltage type megger should be adopted and insulation resistance shall be not less than 5MΩ.
2	Motor thermal protection	If the rated capacity of the selected motor does not match the inverter, especially when the inverter rated power is greater than the motor rated power, be sure to adjust the motor protection parameter values inside inverter or install thermal relay in the front of motor for motor protection.
3	Run over power frequency	The inverter output frequency rang is 0Hz to 3200Hz(Max.vector control only supports 300Hz). If the user is required to run at 50Hz or more, please consider the endurance of your mechanical devices.
4	Vibrations of mechanical device	Inverter output frequency may be encountered mechanical resonance point of the load device, you can set jump frequency parameter inside inverter to avoid the case.
5	Motor heat and noise	The inverter output voltage is PWM wave that contains a certain amount of harmonics, so the temperature rise, noise and vibration of motor show a slight higher than frequency power frequency operation.
6	Output side with piezoresistor or capacitor for proving power factor	The inverter output is PWM wave, if the piezoresistor for lightning protection or the capacitor for improving power factor is installed in the output side, which easily cause the inverter instantaneous overcurrent or even cause damage to the inverter. Please do not use.
7	Contact or switch used in the inverter input/output terminals	If contactor is installed between power supply and inverter, the contactor is not allowed to start/stop the inverter. Necessarily need to use the contactor to control the inverter start/stop, the interval should not be less than one hour. Frequent charging and discharging may reduce the service life of the inverter capacitor. If the contactor or switch is equipped between output terminals and motor, the inverter should be turned on/off without output status, otherwise which easily lead to damage to the inverter module.
8	Use other than the rated voltage	PI series inverter is not suitable for use beyond the allowable operating voltage described in this manual, which easily cause damage to the parts inside inverter. If necessary, please use the corresponding transformer to change voltage.
9	Never change 3-phase input to 2-phase input	Never change PI series 3-phase inverter to 2-phase one for application. Otherwise it will lead to malfunction or damage to the inverter.
10	Lightning surge protection	The series inverter is equipped with lightning overcurrent protection device, so it has the ability of self-protection to lightning induction. For the area where lightning is frequent, user should also install the extra protection in the front of the inverter.
11	High altitude and derating	When the inverter is used in areas over 1000m altitude, it is required to reduce frequency because the thin air will decrease the cooling

No.	Type	Explanation
	application	effect of inverter. Please consult our technician for details on the application.
12	Special use	If the user need to use methods other than the suggested wiring diagram provided in this manual, such as common DC bus, please consult our technician.
13	Precautions for scrap disposal of the inverter	When electrolytic capacitors on the main circuit and printed circuitboard as well as plastic parts are burned, it may produce toxicgases.Please disposing as industrial waste.
14	Adaptive motor	<p>1) Standard adaptive motor shall be four-pole asynchronous squirrel-cage induction motor . Apart from the said motors, please select the inverter according to the motor rated current.</p> <p>2)The cooling fan and the rotor shaft for non-inverter motor are coaxially connected, the fan cooling effect is reduced when the rotational speed is reduced, therefore, when the motor works in overheating occasions, a strong exhaust fan should be retrofitted or replace non-inverter motor with the inverter motor.</p> <p>3) The inverter has built-in the adaptive motor standard parameters, according to the actual situation, please identify motor parameters or accordingly modify the default values to try to meet the actual value, otherwise it will operation affect and protection performance.</p> <p>4)When short-circuit of cable or motor internal will activate the inverter alarm, even bombing. Therefore, firstly perform insulation short-circuit test for the initial installation of the motor and cable,routine maintenance often also need to perform such test. Note that the parts to be tested and the inverter shall be disconnected completely when testing.</p>
15	Others	<p>1) We need to fix cover and lock before power on, so as to avoid the harm to personal safety that is caused by internal injuries of bad capacitors and other components.</p> <p>2)Do not touch internal circuit board and any parts after powering off and within five minutes after keyboard indicator lamp goes out,you must use the instrument to confirm that internal capacitor has been discharged fully, otherwise there is a danger of electric shock.</p> <p>3)Body static electricity will seriously damage the internal MOS field-effect transistors, etc., if there are not anti-static measures, do not touch the printed circuit board and IGBT internal device with hand, otherwise it may cause a malfunction.</p> <p>4) The ground terminal of the inverter(E or PE) shall be earthed firmly according to the provisions of the National Electrical Safety and other relevant standards. Do not shut down(Power off) by pulling switch, and only cut off the power until the motor stopping operation.</p> <p>5)It is required to add the optional input filter attachment so as to meet CE standards.</p>

1-4.Scope of applications

※ This inverter is suitable for three-phase AC asynchronous motor.

※ This inverter can only be used in those occasions recognized by this company, an unapproved use may result in fire, electric shock, explosion and other accidents.

※ If the inverter is used in such equipment (E.g: Equipment for lifting persons, aviation systems,safety equipment, etc.) and its malfunction may result in personal injury or even death. In this case, please consult the manufacturer for your application.

Chapter 2 Standard specifications

2-1. Technical specifications

Model	Rated output power(kW)	Rated input current(A)	Rated output current(A)	Adaptive motor power(kW)	Frame No.
AC 1PH220V(-15%) ~ 240V(+10%)					
PI500-W 0R4G1	0.4	5.4	2.5	0.4	F1
PI500-W 0R7G1	0.75	8.2	4	0.75	F1
PI500-W 1R5G1	1.5	14	7	1.5	F2
PI500-W 2R2G1	2.2	23	10	2.2	F2
PI500-W 004G1	4.0	35	16	4.0	F3
PI500-W 5R5G1	5.5	50	25	5.5	F4
AC 3PH 220V(-15%) ~ 240V(+10%)					
PI500-W 0R4G2	0.4	4.1	2.5	0.4	F1
PI500-W 0R7G2	0.75	5.3	4	0.75	F1
PI500-W 1R5G2	1.5	8.0	7	1.5	F1
PI500-W 2R2G2	2.2	11.8	10	2.2	F2
PI500-W 004G2	4.0	18.1	16	4	F3
PI500-W 5R5G2	5.5	28	25	5.5	F3
PI500-W 7R5G2	7.5	37.1	32	7.5	F4
PI500-W 011G2	11	49.8	45	11	F4
PI500-W 015G2	15.0	65.4	60	15.0	F6
PI500-W 018G2	18.5	81.6	75	18.5	F6
PI500-W 022G2	22.0	97.7	90	22.0	F8
PI500-W 030G2	30.0	122.1	110	30.0	F8
PI500-W 037G2	37.0	157.4	152	37.0	F8
PI500-W 045G2	45.0	185.3	176	45.0	F9
PI500-W 055G2	55.0	214	210	55.0	F9
PI500-W 075G2	75	307	304	75	F10
PI500-W 093G2	93	383	380	93	F11
PI500-W 110G2	110	428	426	110	F11
PI500-W 132G2	132	467	465	132	F13
PI500-W 160G2	160	522	520	160	F13

Model	Rated output power(kW)	Rated input current(A)	Rated output current(A)	Adaptive motor power(kW)	Frame No.
AC 3PH 380V(-15%) ~ 440V(+10%)					
PI500-W 0R7G3	0.75	4.3	2.5	0.75	F1
PI500-W 1R5G3	1.5	5.0	3.8	1.5	F1
PI500-W 2R2G3	2.2	5.8	5.1	2.2	F1
PI500-W 004G3	4.0	10.5	9	4.0	F2
PI500-W 5R5G3	5.5	14.6	13	5.5	F3
PI500-W 7R5G3	7.5	20.5	17	7.5	F3
PI500-W 011F3	11	26	25	11	F3
PI500-W 011G3	11	26	25	11	F3
PI500-W 015F3	15	35	32	15	F4
PI500-W 015G3/018F3	15/18.5	35/38.5	32/37	15/18.5	F4
PI500-W 018G3/022F3	18.5/22	38.5/46.5	37/45	18.5/22	F4
PI500-W 022G3	22	46.5	45	22	F4
PI500-W 030F3	30	62	60	30	F5
PI500-W 030G3	30	62	60	30	F5
PI500-W 037F3	37	76	75	37	F6
PI500-W 037G3/045F3	37/45	76/91	75/90	37/45	F6
PI500-W 045G3	45	91	90	45	F7
PI500-W 055F3	55	112	110	55	F8
PI500-W 055G3	55	112	110	55	F8
PI500-W 075F3	75	157	150	75	F8
PI500-W 075G3	75	157	150	75	F8
PI500-W 093F3	93	180	176	93	F9
PI500-W 093G3/110F3	93/110	180/214	176/210	93/110	F9
PI500-W 110G3/132F3	110/132	214/256	210/253	110/132	F9
PI500-W 132G3	132	256	253	132	F9
PI500-W 160F3	160	307	304	160	F10
PI500-W 160G3/187F3	160/187	307/345	304/340	160/187	F11
PI500-W 187G3/200F3	187/200	345/385	340/380	187/200	F11
PI500-W 200G3/220F3	200/220	385/430	380/426	200/220	F11
PI500-W 220G3	220	430	426	220	F11
PI500-W 250F3	250	468	465	250	F12

Model	Rated output power(kW)	Rated input current(A)	Rated output current(A)	Adaptive motor power(kW)	Frame No.
PI500-W 250G3/280F3	250/280	468/525	465/520	250/280	F12
PI500-W 280G3	280	525	520	280	F12
PI500-W 315F3	315	590	585	315	F13
PI500-W 315G3/355F3	315/355	590/665	585/650	315/355	F13
PI500-W 355G3/400F3	355/400	665/785	650/725	355/400	F13
PI500-W 400G3	400	785	725	400	F13
AC 3PH 480V±10%					
PI500-W 0R7G4	0.75	4.1	2.5	0.75	F1
PI500-W 1R5G4	1.5	4.9	3.7	1.5	F1
PI500-W 2R2G4	2.2	5.7	5.0	2.2	F1
PI500-W 004G4	4.0	9.4	8	4.0	F2
PI500-W 5R5G4	5.5	12.5	11	5.5	F3
PI500-W 7R5G4	7.5	18.3	15	7.5	F3
PI500-W 011F4	11	23.1	22	11	F3
PI500-W 011G4	11	23.1	22	11	F3
PI500-W 015F4	15	29.8	27	15	F4
PI500-W 015G4/018F4	15/18.5	29.8/35.7	27/34	15/18.5	F4
PI500-W 018G4/022F4	18.5/22	35.7/41.7	34/40	18.5/22	F4
PI500-W 022G4	22	41.7	40	22	F4
PI500-W 030F4	30	57.4	55	30	F5
PI500-W 030G4	30	57.4	55	30	F5
PI500-W 037F4	37	66.5	65	37	F6
PI500-W 037G4/045F4	37/45	66.5/81.7	65/80	37/45	F6
PI500-W 045G4	45	81.7	80	45	F7
PI500-W 055F4	55	101.9	100	55	F8
PI500-W 055G4	55	101.9	100	55	F8
PI500-W 075F4	75	137.4	130	75	F8
PI500-W 075G4	75	137.4	130	75	F8
PI500-W 093F4	93	151.8	147	93	F9
PI500-W 093G4/110F4	93/110	151.8/185.3	147/180	93/110	F9
PI500-W 110G4/132F4	110/132	185.3/220.7	180/216	110/132	F9
PI500-W 132G4	132	220.7	216	132	F9

Model	Rated output power(kW)	Rated input current(A)	Rated output current(A)	Adaptive motor power(kW)	Frame No.
PI500-W 160F4	160	264.2	259	160	F10
PI500-W 160G4/187F4	160/187	264.2/309.4	259/300	160/187	F11
PI500-W 187G4/200F4	187/200	309.4/334.4	300/328	187/200	F11
PI500-W 200G4/220F4	200/220	334.4/363.9	328/358	200/220	F11
PI500-W 220G4	220	363.9	358	220	F11
PI500-W 250F4	250	407.9	400	250	F12
PI500-W 250G4/280F4	250/280	407.9/457.4	400/449	250/280	F12
PI500-W 280G4	280	457.4	449	280	F12
PI500-W 315F4	315	533.2	516	315	F13
PI500-W 315G4/355F4	315/355	533.2/623.3	516/570	315/355	F13
PI500-W 355G4/400F4	355/400	623.3/706.9	570/650	355/400	F13
PI500-W 400G4	400	706.9	650	400	F13

Note:

(1)PI500-W frequency inverter PI500-W 132G3 to PI500-W 400G3, with “R” means built-in DC reactor, for example PI500-W 160G3R, PI500-W 160G4R .

(2)The correct option of frequency inverter is : Rated output current of frequency inverter \geq rated current of motor, and the capacity of overload should be considered;

The power difference between rated power of frequency inverter and motor should be less than two class;

While big frequency inverter loading smaller motor, the correct motor parameters should be input in case the motor be damaged by overload.

2-2.Standard specifications

Items		Specifications	
Power input	Rated voltage	AC 1PH 220V(-15%)~240V(+10%) AC 3PH 220V(-15%)~240V(+10%) AC 3PH 380V(-15%)~440V(+10%) AC 3PH 480V(-10%)~480V(+10%)	
	Input frequency	50Hz/60Hz	
	Allowable fluctuation	Voltage:±10%	Voltage unbalance rate is less than 3%
Input frequency:±5%;		Aberration rate meet IEC61800-2 standard	
Control system	Control system	High performance vector control inverter based on DSP	
	Control method	V/F control, vector control W/O PG,	
	Automatic torque boost function	Realize low frequency (1Hz) and large output torque control under the V/F control mode.	
	Acceleration/deceleration control	Straight or S-curve mode. Four times available and time range is 0.0~6500.0s.	
	V/F curve mode	Linear, square root/m-th power, custom V/F curve	
	Over load capability	G type:Rated current 150% -1 minute, rated current 180%-2seconds	

Items		Specifications	
		F type:Rated current 120% -1 minute, rated current 150%-2seconds	
	Maximum frequency	1.Vector control:0~300Hz;2.V/F control:0~3200Hz	
	Carrier Frequency	0.5~16kHz; automatically adjust carrier frequency according to the load characteristics.	
	Input frequency resolution	Digital setting0.01HzMinimum analog:0.01Hz	
	Start torque	G type:0.5Hz/150% (Vector control W/O PG) F type: 0.5Hz/100% (Vector control W/O PG)	
	Speed range	1:100(Vector control W/PG)	
	Steady-speed precision	Vector control W/O PG: $\leq \pm 0.5\%$ (Rated synchronous speed)	
	Torque response	$\leq 40\text{ms}$ (Vector control W/O PG)	
	Torque boost	Automatic torque boost; manual torque boost(0.1%~30%)	
	DC braking	DC braking frequency: 0.0Hz~max. frequency, braking time: 0.0~100.0 seconds, braking current value: 0.0%~100.0%	
	Jogging control	Jog Frequency Range: 0.00Hz~max. frequency; Jog Ac/deceleration time: 0.0s~6500.0s	
	Multi-speed operation	Achieve up to 16-speed operation through the control terminal	
	Built-in PID	Easy to realize closed-loop control system for the process control.	
	Automatic voltage regulation(AVR)	Automatically maintain a constant output voltage when the voltage of electricity grid changes	
	Constant pressure water supply special function	Automatic pump increase, automatic pump reduction, low pressure and high pressure alarm, multi-stage pressure water supply time period and pressure setting, motor power frequency conversion attribute selection, timing pump change, etc.	
Personalization function	Self-inspection of peripherals after power-on	After powering on, peripheral equipment will perform safety testing, such as ground, short circuit, etc.	
	Common DC bus function	Multiple inverters can use a common DC bus	
	Quick current limiting	The current limiting algorithm is used to reduce the inverter overcurrent probability, and improve whole unit antiinterference capability.	
	Timing control	Timing control function;time setting max 6500min	
Running	Input signal	Runing method	Keyboard/terminal/communication
		Frequency setting	Analog setting DC 0~10V/0~20mA including adjustable ,panel potentiometer setting, Communication setting, keyboard setting.
		Start signal	Rotate forward/reverse
		Emergency stop	Interrupt controller output
		Wobbulate run	Process control run

Items		Specifications	
	Fault reset	When the protection function is active, you can automatically or manually reset the fault condition.	
	PID feedback signal	Including DC(0~10V), DC(0~20mA)	
	Output Signal	Running status	Motor status display, stop, ac/deceleration, constant speed, program running status.
		Fault output	Contact capacity :Normally open contact 5A/AC 250V,1A/DC 30V.
		Analog output	Two-way analog output, 16 signals can be selected such as frequency, current, voltage and other, output signal range (0~10V / 0~20mA).
		Output signal	Up~8 output signals
	Run function	Limit frequency, jump frequency, frequency compensation, auto-tuning, PID control	
	DC braking	Built-in PID regulates braking current to ensure sufficient braking torque under no overcurrent condition	
Protection function	Inverter protection	Overvoltage protection, undervoltage protection, overcurrent protection, overload protection, overheat protection, overcurrent stall protection, overvoltage stall protection, losing-phase protection (Optional), External fault,communication error, PID feedback signal abnormalities,short circuit to ground protection.	
	IGBT temperature display	Displays current temperature IGBT	
	Inverter fan control	Can be set	
	Instantaneous power down restart	Less than 15 milliseconds: Continuous operation Less than 15 milliseconds: Automatic detection of motor speed, start tracking the motor current speed	
	Speed start tracking method	The inverter automatically tracks motor speed after it start	
	Parameter protection function	Protect inverter parameters by setting administrator password and decoding	
Display	LED/OLED display keyboard	Running information	Monitoring objects including: Running frequency, set frequency, bus voltage, output voltage, output current, output power, output torque, input terminal status, output terminal status, analog AI1 value, analog AI2 value, motor actual running speed,PID set value percentage, PID feedback value percentage.
		Error message	At most save three error message, the fault type, voltage, current, frequency and work status can be queried when the failure is occurred.
	LED display	Display parameters	
	OLED display	Optional, prompts operation content in Chinese/English text.	
	Copy parameter	Can upload and download function code information of frequency inverter rapid replication parameters.	
	Key lock and function selection	Lock part or all of keys, define the function scope of some keys to prevent misuse.	

Items		Specifications
Communication	RS485	Built-in 485
Environment	Environment temperature	-10℃ to 40℃ Temperature at 40 ℃ to 50℃, please derating for use)
	Storage temperature	-20 ℃~65 ℃
	Environment humidity	Less than 90% R.H, no condensation.
	Vibration	Below 5.9m/s ² (= 0.6g)
	Application sites	Indoor where no sunlight or corrosive, explosive gas and water vapor, dust, flammable gas,oil mist, water vapor, drip or salt etc.
	Altitude	It is normally used when altitude less than 1000m. For areas over 1000m , please derate 1% per 100m, max altitude 3000m.
	Protection level	IP20
Product standard	Product adopts safety standards.	IEC61800-5-1
	Product adopts EMC standards.	IEC61800-3
Cooling method		Forced air cooling

Chapter 3 Keyboard

3-1.Keyboard description











Figure 3-1:Operation panel display

3-2.Keyboard indicators

Indicator flag		Name		
Status lamp	RUN	Running indicator light * ON: The inverter is working * OFF:The inverter stops		
	LOCAL/REMOTE	Command indicator light That is the indicator for keyboard operation, terminal operation and remote operation (Communication control) * ON: Terminal control working status * OFF: Teyboard control working status * Flashing: Remote control working status		
	FWD/REV	Forward/reverse running light * ON: In forward status * OFF: In reversal status		
	TUNE/TC	Motor self-learning/Fault indicator * Slow flashing: In the motor self-learning status * Quick flashing: In the fault status		
Units combination indicator	HzAV		Hz	Frequency unit
			A	Current unit
			V	Voltage unit
			RPM	Speed unit
			%	Percentage

3-3.Description of operation panel keys

Sign	Name	Function
	Parameter Setting/Esc Key	* Enter into the modified status of main menu * Esc from functional parameter modification * Esc sub menu or functional menu to status menu
	Shift Key	*Choose displayed parameter circularly under running or stop interface; choose parameter's modified position when modify parameter
	Increasing Key	Parameter or function number increasing, set by parameter F6.18.
	Decreasing key	Parameter or function number decreasing, set by parameter F6.19.
	Running key	For starting running in the mode of keyboard control status
	Stop/Reset Key	*For stopping running in the running status; for resetting the operation in fault alarm status. The function of the key is subject to F6.00
	Enter key	*Step by step into the menu screen, confirm the parameter setting
	Quick multi function key	This key function is determined by the function code F6.21.
	Keyboard encoder	* In query status, function parameter increasing or decreasing * In modified status, the function parameter or modified position increasing or decreasing. * In monitoring status, frequency setting increasing or decreasing

3-4.Keyboard display letters and numbers correspondence table

Digital display area	Display letters	Corresponding letters	Display letters	Corresponding letters	Display letters	Corresponding letters
	0	0	1	1	2	2
	3	3	4	4	5	5
	6	6	7	7	8	8
	9	9	A	A	b	B
	C	C	d	d	E	E
	F	F	H	H	I	I
	L	L	N	N	n	n
	o	o	P	P	r	r
	S	S	t	t	U	U
	T	T	-	-	-	-
y	y					

3-5.Example of parameter settings

3-5-1.Instructions on viewing and modifying function code

PI500-W inverter’s operation panel is three levels menu for parameter setting etc.Three levels: Function parameter group (Level 1)→function code(Level 2)→function code setting(Level 3). The operation is as following:

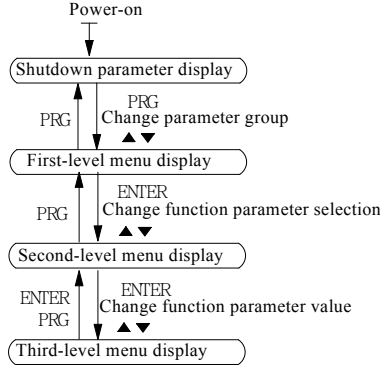
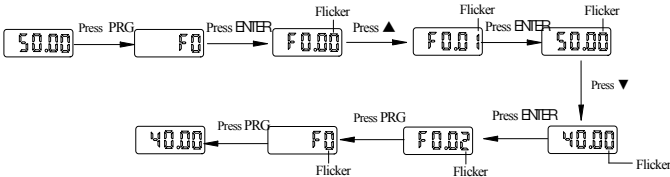

Figure 3-2:Operation processes

Description: Back to the level 2 menu from level 3 menu by PRG key or ENTER key in the level 3 operation status. The differences between the two keys : ENTER will be back to the level 2 menu and save parameter setting before back, and transfer to the next function code automatically; PRG will be back to the level 2 menu directly, not save parameter setting, then back to current function code.

Example 1 Frequency setting to modify parameters
Set FO.01 from 50.00Hz~40.00Hz



Example 2 :Restore factory settings

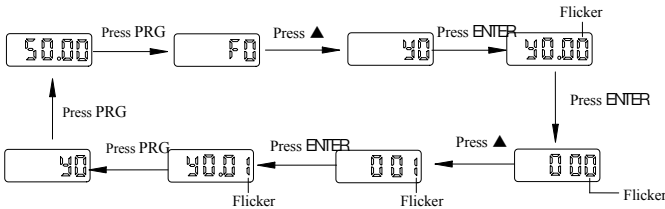

Without twinkling parameter position, the function code can not be modified in the level 3 menu. The reason maybe as following:

- 1) The function code can not be modified itself, eg: Actual detecting parameters, running record parameters.
- 2) The function code can not be modified in the running status. It must be modified in the stop status.

3-5-2. The way to read parameters in various status

In stop or run status, operate shift key  to display a variety of status parameters respectively. Parameter display selection depends on function code F6.01 (Run parameter 1), F6.02 (Run parameter 2) and F6.03 (Stop parameter 3).

In stop status, the stop status parameters that can be set to display/not display, they are: set frequency, bus voltage, DI input status, DO output status, analog input AI1 voltage, analog input AI2 voltage, panel potentiometer actual speed display, PID settings, switch and display the selected parameter by pressing key orderly.

In running status, there are 5 running-status parameters: Running frequency, setting frequency, bus voltage, output voltage, output current default display, and other display parameters: Output power, output torque, DI input status, DO output status, analog input AI1 voltage, analog input AI2 voltage, panel potentiometer ,, PID settings and PID feedback, etc, their display depends on function code F6.01 and F6.02 switch and display the selected parameter by pressing key orderly.

Inverter powers off and then powers on again, the displayed parameters are the selected parameters before power-off.

3-5-3. Password settings

The inverter has password protection. When y0.01 become not zero, it is the password and will be work after exit from function code modified status. Press PRG key again, will display"----". One must input the correct password to go to regular menu, otherwise, inaccessible.

To cancel the password protection function, firstly enter correct password to access and then set y0.01 to 0.

3-5-4. Motor parameter auto tuning

Choose vector control, one must input the motor's parameters in the nameplate accurately before running the inverter. P1500-W series frequency inverter will match the motor's standard parameters according to its nameplate. The vector control is highly depend on motor's parameters. The parameters of the controlled motor must be inputted accurately for the good control performance.

Motor parameter auto tuning steps are as follows(asynchronous motor as an example).

Firstly select command source (F0.11=0) as the comment channel for operation panel, then input the following parameters according to the actual motor parameters (Selection is based on the current motor):

Motor selection	Parameters	
Motor	b0.00:Motor type selection	b0.03:Motor rated current
	b0.01:Motor rated power	b0.04:Motor rated frequency
	b0.02:Motor rated voltage	b0.05: Motor rated speed

If the motor can not completely disengage its load, please select 1 (Synchronous motor parameter static auto tuning) for b0.27, then press the RUN key on the keyboard panel.

If the motor can completely disengage its load, please select 2 (Synchronous motor parameter comprehensive auto turning) for b0.27, and then press the RUN key on the keyboard panel, the inverter will automatically calculate the motor's following parameters:

Motor selection	Parameters
Motor	b0.06:Asynchronous motor stator resistance b0.09:Asynchronous motor mutual inductance b0.07:Asynchronous motor rotor resistance b0.10:Asynchronous motor no-load current b0.08:Asynchronous motor leakage inductance

Complete motor parameter auto tuning

Chapter 4 Installation and commissioning

4-1.Installation direction and space

PI500-W series inverter according to different power rating, the requirements of around installation reserve space is different, specifically as shown below:

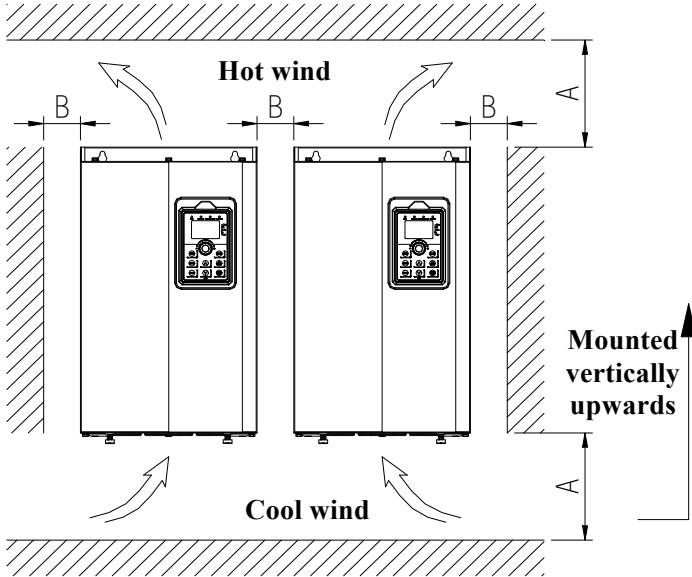

Figure 4-1:PI500-W Series Each power level installation space requirement

Power rating	Dimension requirement
0.75~11kW	$A \geq 100\text{mm}; B \geq 10\text{mm}$
15~22kW	$A \geq 200\text{mm}; B \geq 10\text{mm}$
30~75kW	$A \geq 200\text{mm}; B \geq 50\text{mm}$
93~400kW	$A \geq 300\text{mm}; B \geq 50\text{mm}$

PI500-W Series frequency inverter heat radiator circulated from bottom to top, when more than one inverter work together, usually mounted side by side. In the case of the need to install them by upper and lower rows, due to the heat of the lower inverters rising to the upper equipment, fault maybe caused, heat insulation deflector and other objects to be installed.

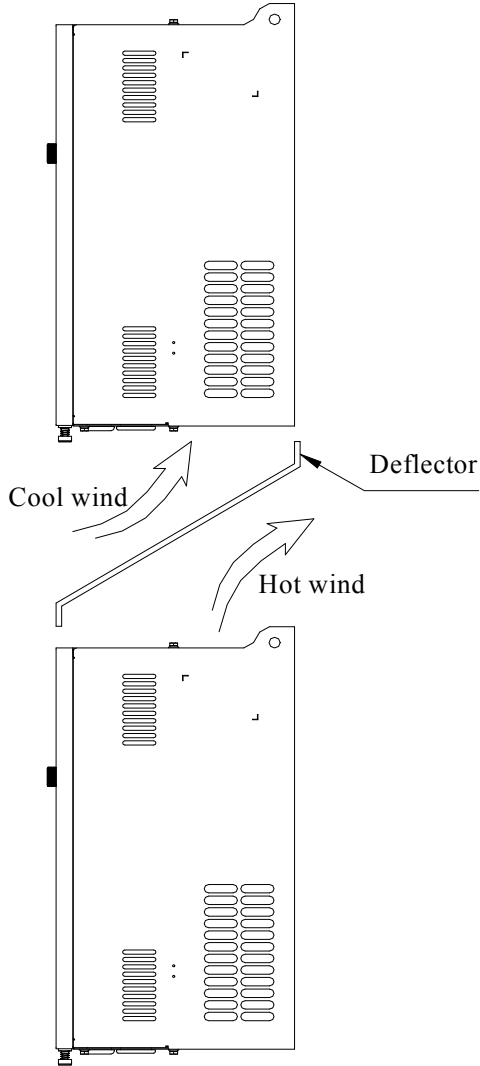
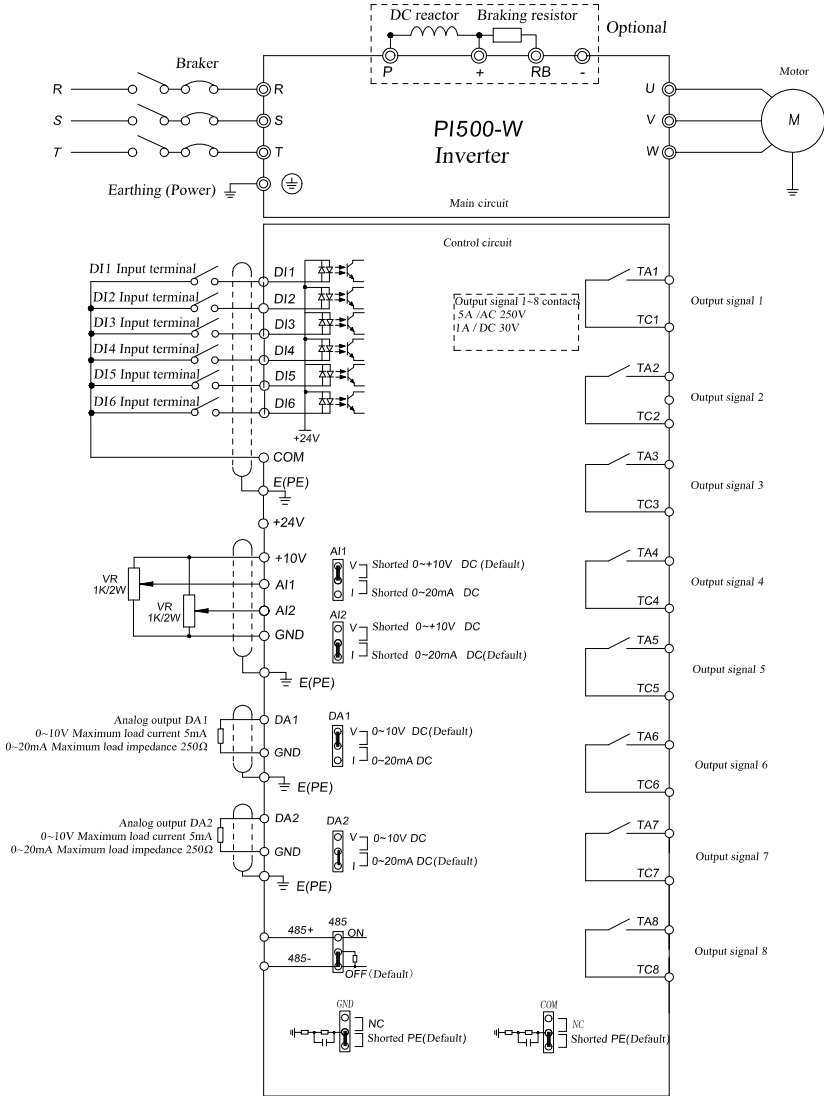

Figure 4-2: Heat insulation deflector up and down installation diagram

4-2. Wiring Diagram

Frequency inverter wiring is divided by main circuit and control circuit. Users must properly connect frequency inverter in accordance with the wiring connection diagram showing below.

4-2-1. Wiring diagram



Figuer 4-3:Wiring diagram

4-3. Main circuit terminal

4-3-1. Main circuit terminal arrangement

1.0.75 ~ 4kW G3 main circuit terminal (plastic shell)

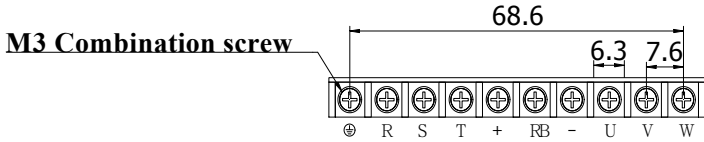

Figure 4-4: 0.75 ~ 4kW G3 main circuit terminal (Frame No.: F1 ~ F2)

2.5.5 ~ 11kW G3 main circuit terminal (plastic shell)

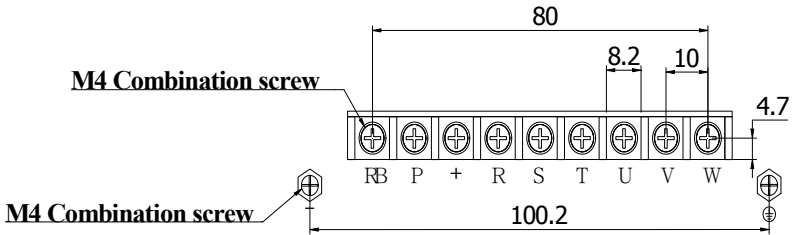

Figure 4-5: 5.5 ~ 11kW G3 main circuit terminal (Frame No.: F3)

3.15 ~ 22kW G3 main circuit terminal (plastic shell)

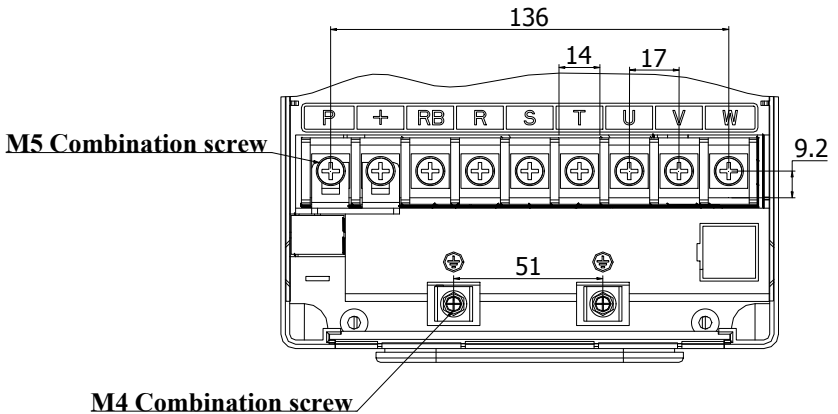

Figure 4-6: 15 ~ 22kW G3 main circuit terminal (Frame No.: F4)

4.30kW G3/F3main circuit terminal

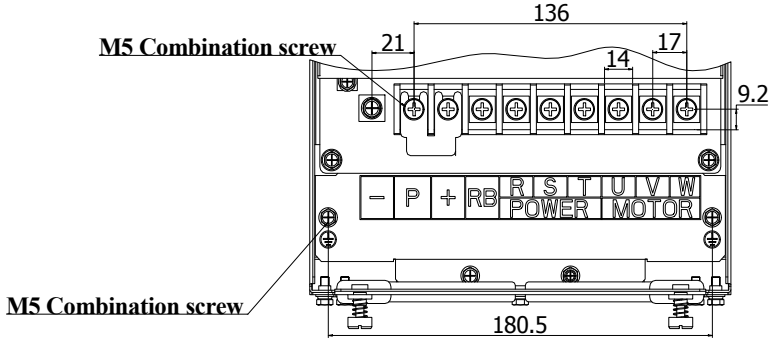

Figure 4-7: 30kW G3/F3main circuit terminal (Frame No.: F5)

5.37kW G3/F3main circuit terminal

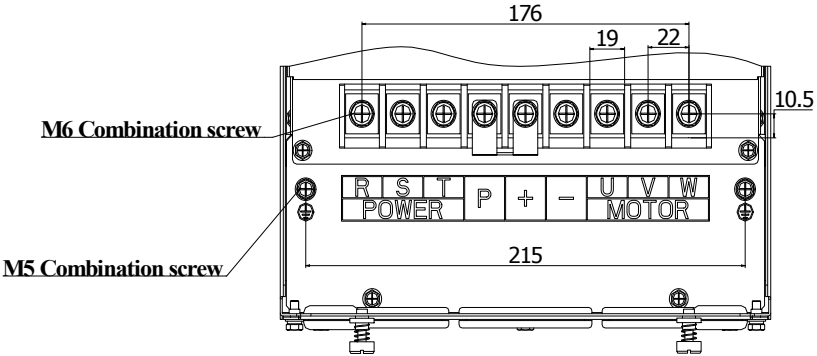

Figure 4-8: 37kW G3/F3main circuit terminal (Frame No.: F6)

6.045G3main circuit terminal

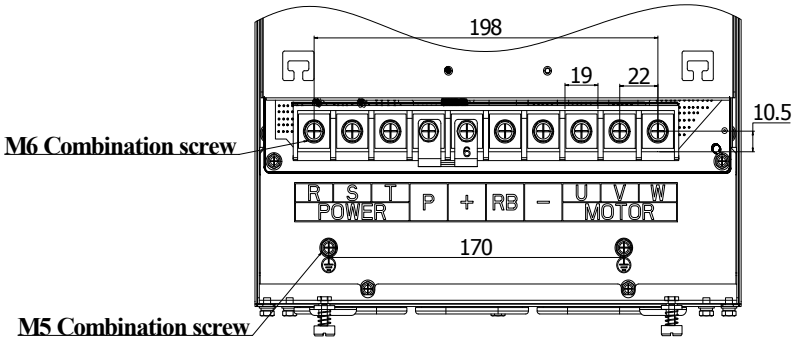

Figure 4-9: 045G3main circuit terminal (Frame No.: F7)

7.55 ~ 75kW G3 main circuit terminal

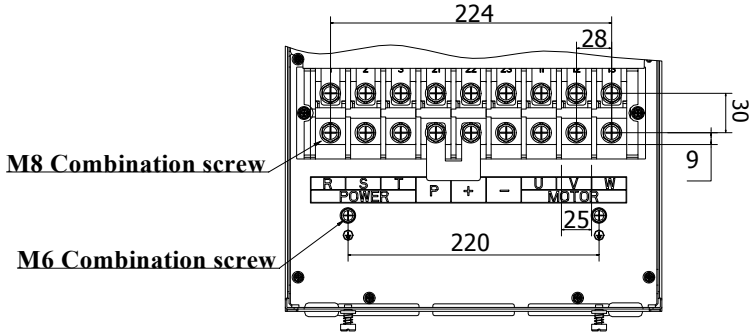

Figure 4-10: 55 ~ 75kW G3 main circuit terminal (Frame No.: F8)

8.93 ~ 132kW G3 main circuit terminal

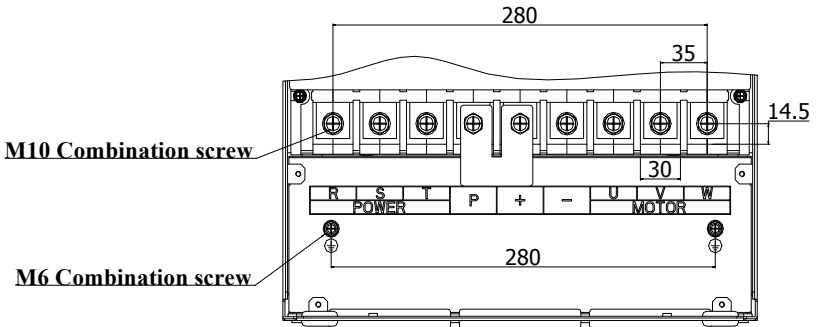

Figure 4-11: 93 ~ 132kW G3 main circuit terminal (Frame No.: F9)

9.160kW F3 main circuit terminal

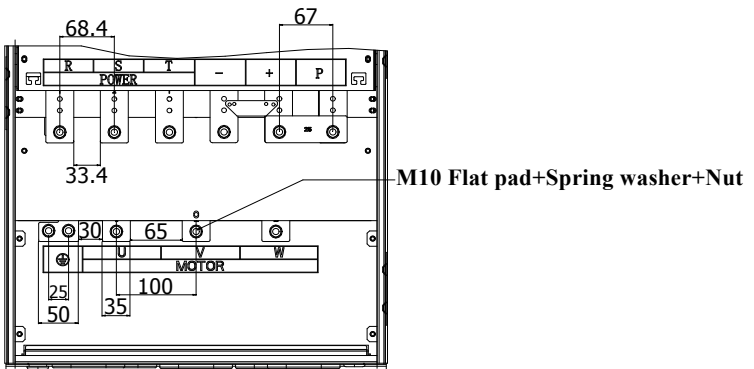

Figure 4-12: 160kW F3 main circuit terminal (Frame No.: F10)

10.160 ~ 220kW G3 main circuit terminal

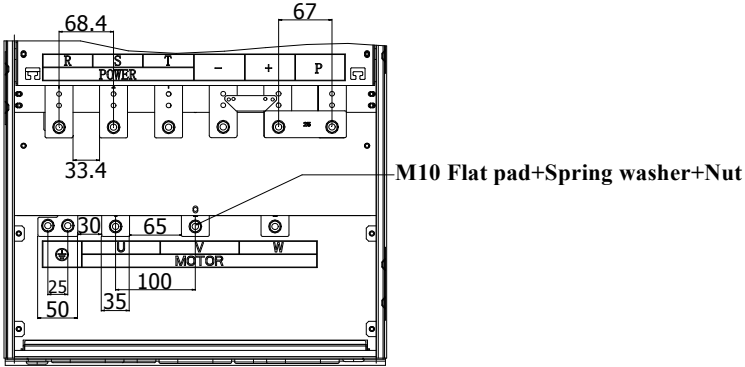

Figure 4-13: 160 ~ 220kW G3 main circuit terminal (Frame No.: F11)

11.250 ~ 400kW G3 main circuit terminal

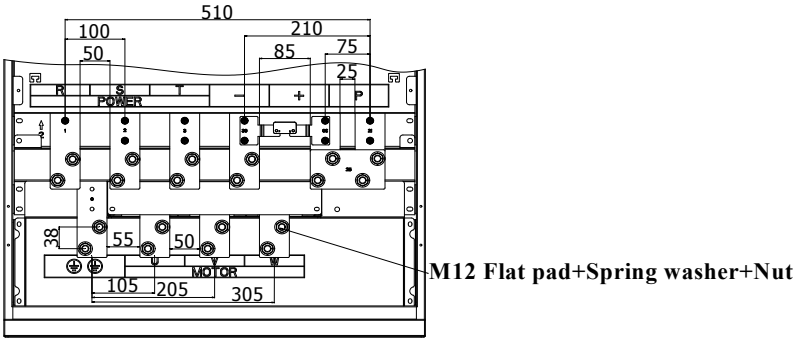

Figure 4-14: 250 ~ 400kW G3 main circuit terminal (Frame No.: F12 ~ F13)

4-3-2.Function description of main circuit terminal

Terminal	Name	Explain
R,S,T	Inverter input terminals	Connect to three-phase power supply, single-phase connects to R, T
⊕	Ground terminals	Connect to ground
+,RB	Braking resistor terminals	Connect to braking resistor
U,V,W	Output terminals	Connect to three-phase motor(Forbidden to connect to single phase AC motors)
+,-	DC bus output terminals	Connect to braking unit
P,+	DC reactor terminals	Connect to DC reactor(Remove the shorting block)

4-3-3. Varistor and safety capacitor switch

For the power grid system with neutral grounding, the customer needs to close the varistor switch (VDR) and safety capacitor switch (EMC) by himself (i.e. press the switch "1");

If it is used in its power grid system (neutral point to ground insulation or high impedance grounding), the varistor (VDR) to ground switch and the safety capacitor (EMC) to ground switch need to be disconnected, as shown in the figure below ("0" press down state is off state), and the filter cannot be installed, otherwise the inverter may be damaged.

In the case of configuration of residual current circuit breaker, if leakage protection occurs during starting, the safety capacitor (EMC) ground switch can be disconnected, as shown in the figure below.

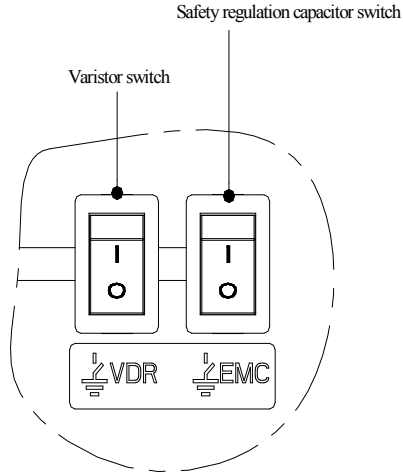
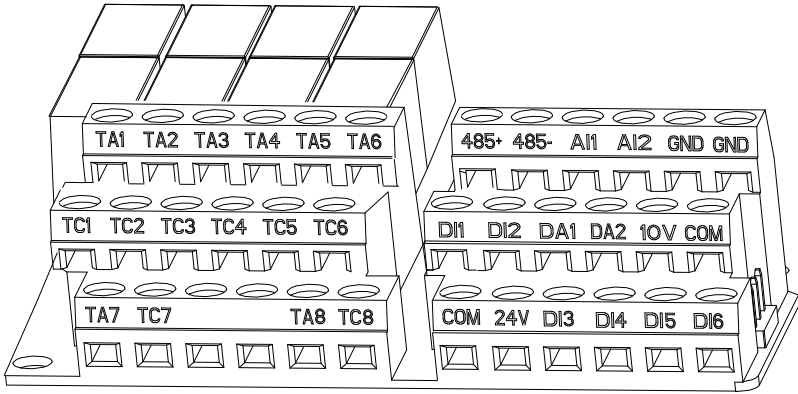

Figure 4-15: Schematic diagram of varistor switch (VDR) and safety capacitor switch (EMC)

4-4.Control circuit terminals

4-4-1.Control circuit terminals arrangement

1.Control panel control circuit terminals



Figuer 4-16:Control panel control circuit terminals

4-4-2.Description of control circuit terminals

Category	Symbol	Name	Function
Power supply	+10V-GND	+ 10V power supply	Output +10V power supply, maximum output current: 10mA Generally it is used as power supply of external potentiometer, potentiometer resistance range: 1kΩ~5kΩ
	+24V-COM	+24V power supply	Output +24V power supply, generally it is used as power supply of digital input and output terminals and external sensor.Maximum outputcurrent:200mA
Analog input	AI1-GND	Analog input terminal 1	1.Input range:(DC 0V~10V/0~20mA), depends on the selected AI1 jumper on control panel. 2.Input impedance: 20kΩ with voltage input, 500Ω with current input.
	AI2-GND	Analog input terminal 2	1.Input range:(DC 0V~10V/0~ 20mA), depends on the selected AI2 jumper on control panel. 2.Input impedance: 20kΩ with voltage input, 500Ω with current input.
Digital input	DI1	Multi-function digital input 1	1.Input impedance: 3.3kΩ 2.Voltage range with level input: 19.2V to 28.8V;
	DI2	Multi-function digital input 2	
	DI3	Multi-function digital input 3	
	DI4	Multi-function digital input 4	
	DI5	Multi-function digital input 5	
	DI6	Multi-function digital input 6	

Analog output	DA1-GND	Analog output 1	The selected DA1 jumper on control panel determines voltage or current output. Output voltage range: 0V~10V , output current range: 0mA~20mA
	DA2-GND	Analog output 2	The selected DA2 jumper on control panel determines voltage or current output. Output voltage range: 0V~10V , output current range: 0mA~20mA
Relay output	TA-TC	Normally open terminals (TA1-TC1)to(TA8-TC8)	Contactor drive capacity: contact 5A/AC 250V 1A/DC 30V;COSφ=0.4.
Built-in RS485	485+	485 differential signal + terminal	485 communication interface, 485 differential signal terminal, use twisted-pair or shielded wire connect to the standard 485 communication interface 485 jump line in the control panel to decide whether to connect the terminal resistance
	485-	485 differential signal - terminal	
Auxiliary interface	GND	GND ground interface	GND jump line decide whether to connect PE, improve the inverter anti-interference
Interface	COM	COM ground interface	COM jump line decide whether to connect PE, improve the inverter anti-interference

Signal input terminal circuit

Switch input and output signal transmission, generally use the shielded cable and wiring short distance as far as possible, good grounding and shielding layer on the inverter side, try not to over 20 m transmission distance. Drive in active way, elected to the power of crosstalk necessary filtering measures are taken, generally recommend that choosedry contact control mode.

Wiring control cables should be kept with the main circuit and high voltage lines (Such as the power cord, motor connecting line, relay or contactor) more than 20cm distance, and to avoid high voltage lines parallel to and can't be avoided and the high voltage lines cross, the proposal USES vertical wiring way, in order to prevent the misoperati on caused by disturbance frequency converter

Dry contact mode:

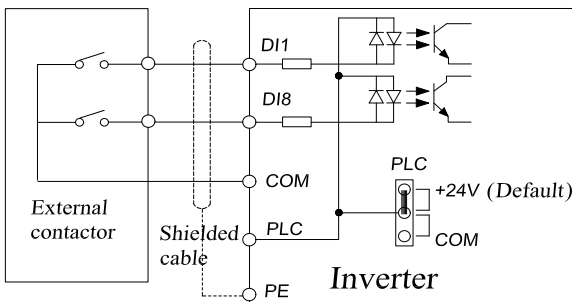

Inner power supply with main connect

Figure 4-17: Signal input terminal circuit- dry contact mode

Open collector NPN connect wire:

When the input signal from the NPN transistor, according to the use of power supply, please according to the figure + 24 v and PLC jumper cap.

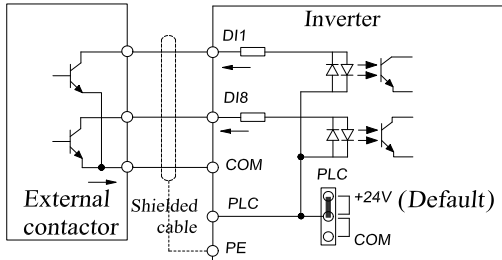

Inner power NPN connect mode

Figure 4-18: Signal input terminal wiring diagram open collector NPN connection mode

4-5. Wiring Precautions

<p>⚠ Danger</p> <p>Make sure that the power switch is in the OFF state before wiring operation, or electrical shock may occur! Wiring must be performed by a professional trained personnel, or this may cause damage to the equipment and personal injury! Must be grounded firmly, otherwise there is a danger of electric shock or fire hazard !</p>
<p>⚠ Note</p> <p>Make sure that the input power is consistent with the rated value of inverter, otherwise which may cause damage to the inverter! Make sure that the motor matches the inverter, otherwise which may cause damage to the motor or activate the inverter protection! Do not connect power supply to U, V, W terminals, otherwise which may cause damage to the inverter! Do not directly connect braking resistor to DC bus (P), (+) terminals, otherwise which may cause a fire!</p>

- ※ The U, V, W output end of inverter can not install phase advancing capacitor or RC absorbing device. The inverter input power must be cut off when replacing the motor
- ※ Do not let metal chips or wire ends into inside the inverter when wiring, otherwise which may cause malfunction to the inverter.
- ※ Disconnect motor or switch power-frequency power supply only when the inverter stops output. In order to minimize the effects of electromagnetic interference, it is recommended that a surge absorption device shall be installed additionally when electromagnetic contactor and relay is closer from the inverter.
- ※ External control lines of inverter shall adopt isolation device or shielded wire.
- ※ In addition to shielding, the wiring of input command signal should also be aligned separately, it is best to stay away from the main circuit wiring.
- ※ If the carrier frequency is less than 3KHz, the maximum distance between the inverter and the motor should be within 50 meters; if the carrier frequency is greater than 4KHz, the distance should be reduced appropriately, it is best to lay the wiring inside metal tube.
- ※ When the inverter is additionally equipped with peripherals (Filter, reactor, etc.), firstly measure its insulation resistance to ground by using 1000 volt megger, so as to ensure the

measured value is no less than 4 megohms.

※ When the inverter need to be started frequently, do not directly turn power off, only the control terminal or keyboard or RS485 operation command can be used to control the start/stop operation, in order to avoid damage to the rectifier bridge.

※ To prevent the occurrence of an accident, the ground terminal(\perp) must be earthed firmly(grounding impedance should be less than 10 ohms), otherwise the leakage current will occur.

※ The specifications on wires used by the main circuit wiring shall comply with the relevant provisions of the National Electrical Code.

※ The motor's capacity should be equal to or less than the inverter's capacity.

Chapter 5 Function parameter

5-1.Menu grouping

Note:

“★”: In running status, can not modify the parameter setting

“●”: The actual testing data, can not be modified

“☆”: In stop and run statuses, both can be changed;

“▲”: “Factory parameter”, no change about it.

“_” means the factory parameter is related to power or model. Please check the details in theinvolved parameter introduction.

y0.01 is used for parameters protection password. Parameter menu can be enter into only after inputting the right password in the function parameter mode or user change parameter mode. When the y0.01 set to 0, the password is canceled.

Parameter menu is not protected by password under user customized parameters mode.

F group is the basic function parameters,E group is to enhance function parameters, b group is a function of motor parameters,d group is the monitoring function parameters.

Note: Some parameters of PI500-W constant voltage water supply special inverter are “factory reserved”, the serial number is not listed in the function parameter table, and some parameter numbers in the table are not connected. For the parameters not mentioned in the manual, please do not try to make changes to avoid causing errors.

Code	Parameter name	Functional Description
d0	Monitoring function group	Monitoring frequency, current, etc
F0	Basic function group	Frequency setting, control mode, acceleration and deceleration time
F1	Input terminals group	Analog and digital input functions
F2	Output terminals group	Analog and digital output functions
F3	Start and stop control group	Start and stop control parameters
F4	V/F control parameters	V/F control parameters
F5	Vector control parameters	Vector control parameters
F6	Keyboard and display	To set key and display function parameters
F7	Auxiliary function group	To set Jog, jump frequency and other auxiliary function parameters
F8	Fault and protection	To set fault and protection parameters
F9	Communication parameter group	To set MODBUS communication function
FA	Torque control parameters	To set parameters under torque control mode
Fb	Control optimization parameters	To set parameters of optimizing the control performance
FC	Extend parameters group	Special application parameters setting
E0	Wobblulate, fixed-length and counting	To set Wobblulate, fixed-length and counting function parameters
E1	Multi-stage command, simple PLC	Multi-speed setting, PLC operation
E2	PID function group	To set Built-in PID parameters

E3	Virtual DI, Virtual DO	Virtual I/O parameter setting
E8	Constant pressure water supply special group	Special parameter setting for constant pressure water supply
b0	Motor parameters	To set motor parameter
y0	Function code management	To set password, parameter initialization and parameter group display
y1	Fault query	Fault message query

5-1-1.d0 group - Monitoring function group

Code	Parameter name	Setting range	Factory setting
d0.00	Running frequency	Theoretical output frequency	0.01Hz
d0.01	Set frequency	Actual set frequency	0.01Hz
d0.02	DC bus voltage	Detected value for DC bus voltage	0.1V
d0.03	Output voltage	Actual output voltage	1V
d0.04	Output current	Effective value for actual motor current	0.01A
d0.05	Output power	Calculated value for motor output power	0.1kW
d0.06	Output torque	Motor output torque percentage	0.1%
d0.07	DI input status	DI input status	-
d0.08	DO output status	DO output status	-
d0.09	AI1 voltage (V)	AI1 input voltage value	0.01V
d0.10	AI2 voltage (V)	AI2 input voltage value	0.01V
d0.14	Actual operating speed	Motor actual running speed	-
d0.15	PID setting	Reference value percentage when PID runs	%
d0.16	PID feedback	Feedback value percentage when PID runs	%
d0.19	Feedback speed	Actual output frequency	0.01Hz
d0.20	Remaining run time	Remaining run time display, it is for timing run control	0.1Min
d0.22	Current power-on time	Total time of current inverter power-on	1Min
d0.23	Current run time	Total time of current inverter run	0.1Min
d0.25	Communication set value	Frequency, torque or other command values set by communication port	0.01%
d0.27	Master frequency display	Frequency set by F0.03 master frequency setting source	0.01Hz
d0.28	Auxiliary frequency display	Frequency set by F0.04 auxiliary frequency setting source	0.01Hz
d0.35	Inverter status	Display run, standby and other statuses	-
d0.36	Inverter type	1.G type (Constant torque load type) 2.F type (Fans/pumps load type)	-
d0.37	AI1 voltage before correction	Input voltage value before AI1 linear correction	0.01V
d0.38	AI2 voltage before	Input voltage value before AI2 linear correction	0.01V

	correction		
--	------------	--	--

5-1-2.F0 group - Basic function group

Code	Parameter name	Setting range	Factory setting	Change
F0.00	Motor control manner	0.Vector control W/O PG 2.V/F control	2	★
F0.01	Keyboard set frequency	0.00Hz~F0.19 (Maximum frequency)	50.00Hz	☆
F0.02	Frequency command resolution	1: 0.1Hz; 2: 0.01Hz	2	★
F0.03	Frequency source master setting	0: Keyboard set frequency (F0.01, UP/DOWN can be modified, power-down without memory); 1: Keyboard set frequency (F0.01, UP/DOWN can be modified, power-down with memory); 2: Analog AI1 setting; 3: Analog AI2 setting; 4: Keypad potentiometer setting; 8: PID control setting; 9: Remote communications setting	8	★
F0.04	Frequency source auxiliary setting	Same as F0.03	0	★
F0.05	Frequency source auxiliary setting range selection	0: Relative to maximum frequency 1: Relative to master frequency source 1 2:Relative to master frequency source 2	0	☆
F0.06	Frequency source auxiliary setting range	0%~150%	100%	☆
F0.07	Frequency source superimposed selection	Units digit:Frequency source selection Tens digit: Arithmetic relationship of master and auxiliary for frequency source	00	☆
F0.08	Frequency source offset frequency when superimposing	0.00Hz~F0.19(Maximum frequency)	0.00Hz	☆
F0.09	Shutdown memory selection	0: W/O memory; 1: With memory	1	☆
F0.10	Frequency command UP / DOWN reference when running	0: Running frequency; 1: Set frequency	0	★
F0.11	Command source selection	0.Keyboard control (LED off) 1.Terminal block control (LED on) 2.Communications command control (LED flashes) 3. Keyboard control+ Communications command control 4. Keyboard control+ Communications command control+ Terminal block control	4	☆
F0.12	Command frequency synchronization	Units digit: Operation panel command binding frequency source selection	000	☆

		0:No binding; 1: Keypad set frequency; 2:Analog AI1 setting; 3:Analog AI2 setting 4:Keypad potentiometer setting; 8:PID setting; 9:Communication setting Tens digit: Terminal command binding frequency source selection (0~9,same as units digit) Hundreds digit:Communication command binding frequency source selection(0~9,same as)		
F0.13	Acceleration time 1	0.00s~6500s	Depends on models	☆
F0.14	Deceleration time 1	0.00s~6500s	Depends on models	☆
F0.15	Ac/Deceleration time unit	0:1 second; 1:0.1 second; 2:0.01 second	1	★
F0.16	Ac/deceleration time reference frequency	0: F0.19(Maximum frequency) 1: Set frequency 2: 100Hz	0	★
F0.17	Carrier frequency adjustment	0: NO; 1: YES	0	☆
F0.18	Carrier frequency	0.5khz~16.0khz	Depends on models	☆
F0.19	Maximum output frequency	50.00Hz~320.00Hz	50.00Hz	★
F0.20	Upper limit frequency source	0: F0.21 setting; 1: Analog AI1 setting 2: Analog AI2 setting 3: Keypad potentiometer setting 5: Communications reference	0	★
F0.21	Upper limit frequency	F0.23 (Lower limit frequency) ~F0.19(Maximum frequency)	50.00Hz	☆
F0.22	Upper limit frequency offset	0.00Hz~F0.19 (Maximum frequency)	0.00Hz	☆
F0.23	Lower limit frequency	0.00Hz~F0.21 (Upper limit frequency)	20.00Hz	☆
F0.24	Running direction	0: Same direction; 1: Opposite direction	0	☆
F0.26	AI Analog accuracy	0: 0.01Hz; 1: 0.05Hz; 2: 0.1Hz; 3: 0.5Hz	1	☆
F0.27	GF type	1.G type (Constant torque load type) 2.F type (Fans/pumps load type)	-	●

5-1-3.F1 group - Input terminal

Code	Parameter name	Setting range	Factory setting	Change
F1.00	DI1 terminal function selection	52: Motor A Properties	1	★
F1.01	DI2 terminal function selection	53: Motor B Properties 54: Motor C Properties	52	
F1.02	DI3 terminal function selection	55: Motor D Properties 56: Motor E Properties	53	
F1.03	DI4 terminal function selection	57: Motor F Properties 58: Motor G Properties	54	
F1.04	DI5 terminal function selection	59: Motor H Properties 60: Manual control selection :	55	
F1.05	DI6 terminal function selection	0: automatic 1: manual	60	

There are two control modes for constant pressure water supply: automatic control mode and manual control mode, which are selected through DI function 60

Automatic control mode: DI control (F1.01-F1.04) or function code (E8.31-E8.38) can be selected through E8.59 (DI terminal control motor start stop attribute)

Manual control mode: select motor direct power frequency startup by controlling DI

The select able functions are shown in the table below.

Setting value	Function	Description
0	No function	The terminal for not use can be set to "no function" to prevent Accidental operation.
1	Forward run (FWD)	External terminals are used to control the FWD/REV run mode of inverter.
2	Reverse run (REV)	
3	Three-wire operation control	This terminal is used to determine the inverter's three-wire Control mode. For details, please refer to the instructions of function code F1.10 ("Terminal command mode").
4	Forward JOG (F JOG)	FJOG means Forward JOG running, RJOG means Reverse JOG running. For Jog running frequency and Jog Ac/deceleration time, please refer to the description of the function code F7.00, F7.01, F7.02.
5	Reverse JOG (R JOG)	
6	Terminal UP	Modify frequency increment/decrement command when the Frequency is referenced by external terminal. Adjust up/down the set frequency when the digital setting is selected as the frequency source.
7	Terminal DOWN	
8	Free stop	The inverter output is blocked, at the time, the parking process of motor is not controlled by the inverter. This way is same as the principle of free stop described in F3.07.
9	Fault reset (RESET)	The function make use of terminal for fault reset. It has same Function with RESET key on the keyboard. This function can be used to realize remote fault reset.
10	Run pausing	The inverter slows down and stops, but all operating parameters are memorized. Such as PLC parameters, wobble frequency parameters, and PID parameters. This terminal signal disappears, the inverter reverts to the previous state of running before parking.

11	External fault normally open input	When the signal is sent to the inverter, the inverter reports fault Err.15, and performs troubleshooting according to fault protection action (for details, please refer to the function code F8.17).
16	Ac/deceleration time selection terminal 1	The selection of 4 ac/deceleration times can be achieved through the 4 states of the two terminals. For details, see Table 2
17	Ac/deceleration times election terminal 2	
18	Frequency source switching	Used to switch between different frequency sources. According to frequency source selection function code (F0.07) settings, the terminal is used to switch between two frequency sources.
19	UP/DOWN setting clear (terminal, keyboard)	When the frequency reference is the digital frequency, this terminal is used to clear the changed frequency value by terminal UP/DOWN or keyboard UP/DOWN, so that the reference frequency can recover to the set value of F0.01.
20	Run command switch terminal 1	When the command source is set to the terminal control (F0.11 = 1), the terminal can be used to switch between terminal control and keyboard control. When the command source is set to the communication control (F0.11 = 2), the terminal can be used to switch between communication control and keyboard control.
21	Ac/deceleration prohibited	Ensure the inverter is free from external signals affect (except for shutdown command), maintain current output frequency.
22	PID pause	PID is temporarily disabled, the inverter maintains current Output frequency, no longer performs PID adjustment of frequency source.
32	Immediately DC braking	If the terminal is active, the inverter switches directly to DC Braking status
33	External fault normal close input	When the signal of external fault normally closed input is Inputted into the inverter, the inverter will report fault Err.15 and shutdown.
34	Frequency change enable	If the function is set to be valid, when the frequency changes, the inverter does not respond to frequency changes until the terminal state is invalid.
35	PID action directionas reverse	If the terminal is valid, PID action direction opposites to the Direction set by E2.03
36	External stop terminal 1	Under keyboard control mode, the terminal can be used to stop the inverter, same as STOP key on the keyboard.
37	Control command switch terminal 2	Used to switch between terminal control and communication Control. If the command source is selected as terminal control, the system will be switched to the communication control mode when the terminal is active; vice versa.
38	PID integral pause	When the terminal is active, the PID integral adjustment function is paused, but the proportion and differential adjustments of PID are still valid.
39	Switch between frequency source master setting and preset frequency	When the terminal is active, the frequency source A is replaced by the preset frequency (F0.01)

40	Switch between frequency source auxiliary setting and Preset frequency	When the terminal is active, the frequency source B is replaced with the preset frequency (F0.01)		
43	PID parameter switching	When DI terminal (E2.19 = 1) is used to switch PID parameters, if the terminal is invalid, PID parameters use E2.13 to E2.15; if the terminal is valid, PID parameters use E2.16~E2.18		
44	Custom fault1	When custom fault 1 and custom fault 2 are active, the inverter respectively alarms fault Err.27 and fault Err.28, and deals with them according to the mode selected by the fault protection action F8.19.		
45	Custom fault2			
47	Emergency stop	If the terminal is valid, the inverter will park at the fastest speed, and the current maintains at the set upper limit during the parking process. This function is used to meet the requirements that the inverter needs to stop as soon as possible when the system is in an emergency state.		
48	External stop terminal 2	In any control mode (Keyboard control, terminal control, communication control), the terminal can be used to decelerate the inverter until stop, at the time the deceleration time is fixed for deceleration time 4.		
49	Deceleration DC braking	If the terminal is valid, firstly the inverter decelerates to the initial frequency of stop DC braking, and then switches directly to DC braking status.		
50	Clear current running time	If the terminal is valid, the inverter's current running time is cleared.		
F1.10	Terminal command mode	0:Two-wire type 1;1:Two-wire type 2; 2:Three-wire type 1; 3:Three-wire type 2	0	★
F1.11	Terminal UP / DOWN change rate	0.001Hz/s~65.535Hz/s	1.000Hz/s	☆
F1.12	Minimum input for AIC1	0.00V~F1.14	0.30V	☆
F1.13	F1.12 corresponding setting	-100.0%~+100.0%	0.0%	☆
F1.14	Maximum input for AIC1	F1.12~+10.00V	10.00V	☆
F1.15	F1.14 corresponding setting	-100.0%~+100.0%	100.0%	☆
F1.16	Minimum input for AIC2	0.00V~F1.18	0.00V	☆
F1.17	F1.16 Corresponding to the set	-100.0%~+100.0%	0.0%	☆
F1.18	AIC2 max. Input	F1.16~+10.00V	10.00V	☆
F1.19	F1.18 corresponding to the set	-100.0%~+100.0%	100.0%	☆
F1.23	F1.22 corresponding to the set	-100.0% to +100.0%	100.0%	☆
F1.24	AI curve selection	Units digit: AI1 curve selection Tens digit: AI2 curve selection	321	☆

F1.25	AI input setting selection	Units digit: AI1 lower than minimum input setting selection; 0: Correspond to minimum input setting; 1: 0.0%; Tens digit: AI2 lower than minimum input setting selection;	000	☆
F1.30	DI filter time	0.000s~1.000s	0.010s	☆
F1.31	AI1 filter time	0.00s~10.00s	0.10s	☆
F1.32	AI2 filter time	0.00s~10.00s	0.10s	☆
F1.35	DI terminal mode selection 1	Units digit: DI1 0:High level active 1:Low level active Tens digit:DI2(Same as the units digit)	00000	★
F1.37	DI1 delay time	0.0s~3600.0s	0.0s	★
F1.38	DI2 delay time	0.0s~3600.0s	0.0s	★
F1.39	DI3 delay time	0.0s~3600.0s	0.0s	★
F1.40	Define the input terminal repeat	0:Unrepeatable; 1:Repeatable	0	★
F1.42	Keyboard potentiometer X2	0~100.00%	0.50%	☆

5-1-4.F2 group - Output terminals group

Code	Parameter name	Setting range	Factory setting	Change
F2.01	Relay 1 output	21: Motor A variable frequency	21	★
F2.02	Relay 2 output	22: Motor A variable frequency	22	
F2.03	Relay 3 output	23: Motor B variable frequency	23	
F2.04	Relay 4 output	24: Motor B variable frequency	24	
F2.05	Relay 5 output	25: Motor C variable frequency	25	
F2.06	Relay 6 output	26: Motor C variable frequency	26	
F2.07	Relay 7 output	27: Motor D variable frequency	27	
F2.08	Relay 8 output	28: Motor D variable frequency	28	
F2.09		29: Motor E variable frequency		
F2.10	DA1 output	30: Motor E variable frequency	0	

Setting value	Function	Explanation
0	Operating frequency	0 ~ Maximum output frequency
1	Set frequency	0 ~ Maximum output frequency
2	Output Current	0 ~ 2 times the rated motor current
3	Output torque	0 ~ 2 times the rated torque of the motor
4	Output power	0 ~ 2 times rated power
5	Output Voltage	0 ~ 1.2 times the rated voltage of the inverter
6	High-speed pulse input	0.01kHz ~ 100.00kHz
7	Analog AI1	0 ~ 10V (or 0 ~ 20mA)
8	Analog AI2	0 ~ 10V(or 0 ~ 20mA)
9	Analog AI3	0 ~ 10V
10	Length value	0 ~ Maximum set length
11	Counting value	0 ~ Maximum count value
12	Communication settings	0.0% ~ 100.0%
13	Motor speed	0 ~ Speed corresponding to maximum output frequency
14	Output Current	0.0A ~ 100.0A(Inverter power \leq 55kW); 0.0A ~ 1000.0A(Inverter power > 55kW)
15	DC bus voltage	0.0 ~ 1000.0V
16	Reserved	Reserved
17	Frequency source master set	0 ~ Maximum output frequency

The output range of analog output DA1 and DA2 is 0V to 10V or 0mA to 20mA, and the range of pulse output or analog output is calibrated to the corresponding function as shown in the table below:

Setting value	Function	Explanation
F2.13	Relay 1 output delay time	0.0 ~ 3600.0
F2.14	Relay 2 output delay time	0.0 ~ 3600.0
F2.15	Relay 3 output delay time	0.0 ~ 3600.0
F2.16	Relay 4 output delay time	0.0 ~ 3600.0
F2.17	Relay 5 output delay time	0.0 ~ 3600.0
F2.18	Relay 6 output delay time	0.0 ~ 3600.0
F2.19	Relay 7 output delay time	0.0 ~ 3600.0
F2.20	Relay 8 output delay time	0.0 ~ 3600.0

Relays 1 to 5 share the same parameter as the open delay time, while relays 6 to 8 have only the close delay time.

F2.21	DO1 terminal active state selection	ones place	Relay 1 effective state selection	00000	☆	
		positive logic				0
		Anti logic				1
		Ten places	Relay 2 active state (defined in the same bit)			
		Hundredth place	Relay 2 active state (defined by the same bit)			
		thousand places	Relay 4 active state (defined by the same bit)			
		10,000 places	Relay 5 active state (defined by the same digit)			
F2.22	DO2 terminal active state selection	ones place	Relay 6 active state selection	00000	☆	
		Positive Logic				0
		Anti-logic				1
		Ten places	Relay 7 active state (defined by the same digit)			
		Hundredth place	Relay 8 active state (defined by the same bit)			
		thousand places	Reserved			
		10,000 places	Reserved			
F2.23	DA1 zero bias coefficient	-100.0% ~ +100.0%		0.0%	☆	
F2.24	DA1 gain	-10.00 ~ +10.00		1.00	☆	
F2.25	DA2 zero bias coefficient	-100.0% ~ +100.0%		20.0%	☆	
F2.26	DA2 gain	-10.00 ~ +10.00		0.80	☆	

5-1-5.F3 group - Start and stop control group

Code	Parameter name	Setting range	Factory setting	Change
F3.00	Start-up mode	0:Direct startup; 1:Speed tracking restart 2:Pre-excitation start(AC asynchronous motor)	0	☆
F3.01	Speed tracking mode	0~2:Reserve; 3:Rotate speed tracking method	3	★
F3.02	Speed tracking value	1~100	20	☆
F3.03	Start frequency	0.00Hz~10.00Hz	0.00Hz	☆
F3.04	Hold time for start	0.0s~100.0s	0.0s	★

	frequency			
F3.05	DC beforehand field current	0%~100%	0%	★
F3.06	DC excitation time beforehand	0.0s~100.0s	0.0s	★
F3.07	Stop mode	0:Deceleration parking; 1: Free stop	1	☆
F3.08	DC Initial frequency	0.00Hz~F0.19(Maximum frequency)	0.00Hz	☆
F3.09	DC Waiting time	0.0s~100.0s	0.0s	☆
F3.10	Stop DC braking current	0%~100%	0%	☆
F3.11	Stop DC braking time	0.0s~100.0s	0.0s	☆
F3.12	Braking utilization rate	0%~100%	100%	☆
F3.13	Acceleration/ deceleration mode	0:Linear acceleration and deceleration; 1:S curve acceleration and deceleration A 2:S curve acceleration and deceleration B	0	★
F3.14	Proportion of S curve start-section	0.0%~(100.0%~F3.15)	30.0%	★
F3.15	Proportion of Scurve end-section	0.0%~(100.0%~F3.14)	30.0%	★

5-1-6.F4 group - V/F control parameters

Code	Parameter name	Setting range	Factory setting	Change
F4.00	V/F mode setting	0: Straight line V/F 1: Multi-point V/F; 2: Square V/F; 3: 1.2 time V/F 4: 1.4 time v/F; 6: 1.6 time V/F; 8: 1.8 time V/F; 10: V/F Completely separate 11: V/F Half separation;	0	★
F4.01	Torque boost	0.0%(Automatic torque boost) 0.1~30%	0.0%	★
F4.02	Promote cut-off frequency	0.00Hz~F0.19(Maximum frequency)	15.00Hz	★
F4.03	V/F Frequency point1	0.00Hz~F4.05	0.00Hz	★
F4.04	V/F Voltage point1	0.0%~100.0%	0.0%	★
F4.05	V/F Frequency point2	F4.03~F4.07	0.00Hz	★
F4.06	V/F Voltage point2	0.0%~100.0%	0.0%	★
F4.07	V/F Frequency point3	F4.05~b0.04(Rated motor frequency)	0.00Hz	★
F4.08	V/F Voltage point3	0.0%~100.0%	0.0%	★
F4.09	Slip compensation coefficient	0.0%~200.0%	0.0%	☆

F4.10	Overexcitation gain	0~200	80	☆
F4.11	Oscillation suppression gain	0~100	0	☆
F4.12	V/F separation voltage source	0~9	0	☆
F4.13	Voltage digital setting	0V~rated motor voltage	0V	☆
F4.14	Voltage rise time	0.0s~1000.0s	0.0s	☆

5-1-7.F5 group - Vector control parameters

Code	Parameter name	Setting range	Factory setting	Change
F5.00	Speed loop ratio G1	1~100	30	☆
F5.01	Speed loop integral T1	0.01s~10.00s	0.50s	☆
F5.02	Switching frequency 1	0.00~F5.05	5.00Hz	☆
F5.03	Speed loop ratio G2	0~100	20	☆
F5.04	Speed loop integral T2	0.01s~10.00s	1.00s	☆
F5.05	Switching frequency 2	F5.02~F0.19(Max. frequency)	10.00Hz	☆
F5.06	Speed loop integral T2	0:Invalid ; 1:Valid	0	☆
F5.07	Torque upper limit source	0: Function code setting; 1:Analog AI1 setting; 2:Analog AI2setting; 3:Set panel encoder setting; 4:High-speed pulse setting; 5:Communications setting 6:Min(AI1,AI2)setting 7:Max(AI1,AI2)setting 8:Analog AI3 setting	0	☆
F5.08	Upper limit digital setting for torque	0.0%~200.0%	150.0%	☆
F5.09	Vector control differential gain	50%~200%	150%	☆
F5.10	Speed loop filter time constant	0.000s~0.100s	0.000s	☆
F5.11	Vector control overexcitation gain	0~200	64	☆
F5.12	Excitation regulator proportional gain	0~60000	2000	☆
F5.13	Excitation regulator integral gain	0~60000	1300	☆
F5.14	Torque regulator proportional gain	0~60000	2000	☆
F5.15	Torque regulator integral gain	0~60000	1300	☆

5-1-8.F6 group - Keyboard and display

Code	Parameter name	Setting range	Factory setting	Change
F6.00	STOP/RESET key functions	0: STOP/RES key is enabled only under keyboard operation mode 1:STOP/RES key is enabled under Any operation mode	1	☆
F6.01	Running status display parameters 1	0x0000~0xFFFF	001F	☆
F6.02	Running status display	0x0000~0xFFFF	0000	☆

	parameters 2			
F6.03	Stop status display parameters	0x0001~0xFFFF	0033	☆
F6.04	Load speed display coefficient	0.0001~6.5000	3.0000	☆
F6.05	Decimal places for load speed display	0:0 decimal places 2:2 decimal places 1:1 decimal places 3:3 decimal places	1	☆
F6.06	Inverter module radiator temperature	0.0°C~100.0°C	-	●
F6.07	Total run time	0h~65535h	-	●
F6.08	Total power-on time	0h~65535h	-	●
F6.09	Total power consumption	0~65535 degree	-	●
F6.10	Product series number	Frequency inverter series number	-	●
F6.11	Software version number	Control board software version	-	●
F6.13	Communication read and write Data selection	Unit: CRC Error response selection 0: CRC Error response selection; 1: CRC Error response selection Ten : Radio message blocking options 0: Don't block; 1: Block Hundred: Frequency converter fault information to read 0: Read; 1: Don't read	011	☆
F6.16	Monitor selection 2	1Kbit/100bit	10bit/1bit	☆
		Parameter number	Parameter series number	
F6.17	Power correction coefficient	0.00~10.00	1.00	☆
F6.18	Multi function key definition 1	0: UP key is defined as add function key 1: UP key is defined as freely stop key 2: UP key is defined as a forward run 3: UP key is Defined as the reverse operation 4: UP key is defined as positive jog function 5: UP Key is defined as anti-jog function 6: UP key is defined as the UP function keys 7: UP key is defined as the DOWN function keys	0	☆
F6.19	Multi function key definition 2	Same to F6.18	0	☆
F6.20	Keypad lock selection	0: RUN, STOP button valid 1: RUN, STOP, key pad encode valid 2: RUN, STOP, UP, DOWN button valid 3: STOP button valid	0	☆
F6.21	QUICK key function	0: No function; 1: Jog running	1	☆

	selection	2:Shift switch display state 3:FWD/RVS switchover 4:Clear-up UP/DOWN setting 5:Free stop 6: Running command given in sequence		
--	-----------	---	--	--

5-1-9.F7 group - Auxiliary function group

Code	Parameter name	Setting range	Factory setting	Change
F7.00	Jog running frequency	0.00Hz~F0.19(Maximum frequency)	6.00Hz	☆
F7.01	Jog acceleration time	0.0s~6500.0s	5.0s	☆
F7.02	Jog deceleration time	0.0s~6500.0s	5.0s	☆
F7.03	Jog priority	0:Invalid ; 1: Valid	1	☆
F7.04	Jump frequency 1	0.00Hz~F0.19(Maximum frequency)	0.00Hz	☆
F7.05	Jump frequency 2	0.00Hz~F0.19(Maximum frequency)	0.00Hz	☆
F7.06	Jump frequency range	0.00Hz~F0.19(Maximum frequency)	0.00Hz	☆
F7.07	Jump frequency availability	0:Invalid; 1:valid	0	☆
F7.08	Acceleration time 2	0.0s~6500.0s	Depends on models	☆
F7.09	Deceleration time 2	0.0s~6500.0s	Depends on models	☆
F7.10	Acceleration time 3	0.0s~6500.0s	Depends on models	☆
F7.11	Deceleration time 3	0.0s~6500.0s	Depends on models	☆
F7.12	Acceleration time 4	0.0s~6500.0s	Depends on models	☆
F7.13	Deceleration time 4	0.0s~6500.0s	Depends on models	☆
F7.14	Switching frequency point between acceleration time 1 and acceleration time	0.00Hz~F0.19(Maximum frequency)	0.00Hz	☆
F7.15	Switching frequency point between deceleration time 1 and deceleration time	0.00Hz~F0.19(Maximum frequency)	0.00Hz	☆
F7.16	Forward/reverse rotation deadband	0.00s~3600.0s	0.00s	☆
F7.17	Reverse rotation control	0:Enable; 1:Disable	0	☆
F7.18	Operation mode under lower limit frequency	0: Running at lower limit frequency 1:Stop; 2:Zero speed running	0	☆
F7.20	Setting cumulative power-on arrival time	0h~36000h	0h	☆

F7.21	Setting cumulative running arrival time	0h~36000h	0h	☆
F7.22	Start protection selection	0:OFF 1:ON	0	☆
F7.41	Cooling fan control	0: Fan running only when running 1: Fan always running	0	☆
F7.46	Awakens frequency	Dormancy frequency (F7.48) ~maximum frequency (F0.19)	30.00Hz	☆
F7.47	Awakens delay time	0.0s~6500.0s	10.0s	☆
F7.48	Dormancy frequency	0.00Hz~Awakens frequency (F7.46)	25.00Hz	☆
F7.49	Dormancy delay time	0.0s~6500.0s	600.0s	☆
F7.50	All protection lower limit	0.00V~F7.51	3.1V	☆
F7.51	All protection upper limit	F7.50~10.00V	6.8V	☆

5-1-10.F8 group - Fault and protection

Code	Parameter name	Setting range	Factory setting	Change
F8.00	Overcurrent stall gain	0~100	20	☆
F8.01	Overcurrent stall protection current	100%~200%	-	☆
F8.02	Overload protection selection	0:Invalid;1:valid	1	☆
F8.03	Overload protection gain	0.20~10.00	1.00	☆
F8.04	Overload pre-alarm coefficient	50%~100%	80%	☆
F8.05	Over-voltage stall gain	0~100	0	☆
F8.06	Over-voltage stall protection voltage / energy consumption brake voltage	120%~150%	130%	☆
F8.07	Input phase loss protection selection	Units digit:Input phase loss protection selection 0:Invalid 1:Enable Tens digit:Contactor actuation protection 0:Invalid 1:Enable	11	☆
F8.08	Output phase loss protection selection	0:Invalid; 1:Enable	1	☆
F8.09	Short to ground protection	0:Invalid; 1:Valid	1	☆
F8.10	Number of automatic fault reset	0~32767	0	☆
F8.11	Fault DO action	0:OFF; 1:ON	0	☆
F8.12	Fault reset interval	0.1s~100.0s	1.0s	☆

5-1-11.F9group - Communication parameter

Code	Parameter name	Setting range	Factory setting	Change
F9.00	Baud rate	Unit:MODBUS 0:300BPS; 1:600BPS 2:1200BPS; 3:2400BPS 4:4800BPS; 5:9600BPS 6:19200BPS; 7:38400BPS 8:57600BPS; 9:115200BPS	6005	☆
F9.01	Data format	0:No parity (8-N-2) 1:Odd parity (8-E-1) 2:Even parity (8-O-1) 3:No parity (8-N-1)	0	☆
F9.02	This unit address	1~250,0 for broadcast address	1	☆
F9.03	Response delay	0ms~20ms	2ms	☆
F9.04	Communication timeout time	0.0(Invalid); 0.1~60.0s	0.0	☆
F9.05	Date Transmission format	Units digit:MODBUS 0:Non-standard MODBUS protocol 1:Standard MODBUS protocol	31	☆
F9.06	Current resolution	0:0.01A ; 1:0.1A	0	☆

5-1-12.Fb group - Control optimization parameters

Code	Parameter name	Setting range	Factory setting	Change
Fb.00	Fast current limiting manner	0:Invalid 1:Enable	1	☆
Fb.01	Under-voltage point setting	50.0%~ 140.0%	100.0%	☆
Fb.02	Over-voltage point setting	200.0V~ 2500.0V	-	★
Fb.03	Dead band compensation mode selection	0:No compensation 1:Compensationmode1 2:Compensationmode2	1	☆
Fb.04	Current detection compensation	0~ 100	5	☆
Fb.05	Vector optimization without PG mode selection	0: No optimization 1: Optimization mode1 2: Optimization mode2	1	★
Fb.06	Upper limiting frequency for DPWM switching	0.00 ~ 15.00Hz	12.00Hz	☆
Fb.07	PWM modulation manner	0:Invalid 1:Enable	0	☆
Fb.08	Random PWM depth	50.0%~ 140.0%	0	☆

5-1-13.E2 group - PID function

Code	Parameter name	Setting range	Factory setting	Change
E2.00	PID given source	8: Set pressure setting	9	☆

		9: Set pressure setting (adjustable up and down keys)		
E2.02	PID feedback source	10: Select channel according to sensor set in e8.06 (default Ai1)	10	☆
E2.06	PID limit deviation	0.0~100.0%	1.0%	☆
E2.13	Proportional gain KP1	0.0~200.0	50.0	☆
E2.14	Integral time Ti1	0.1~10.0s	1.0s	☆
E2.15	Differential time TD1	0.000~10.000S	0.000s	☆

5-1-14.E3 group - Virtual DI.Virtual DO

Code	Parameter name	Setting range	Factory setting	Change
E3.00	Virtual VDI1 terminal function selection	Same as F1.00~F1.07	0	★
E3.01	Virtual VDI2 terminal function selection	Same as F1.00~F1.07	0	★
E3.02	Virtual VDI3 terminal function selection	Same as F1.00~F1.07	0	★
E3.03	Virtual VDI4 terminal function selection	Same as F1.00~F1.07	0	★
E3.04	Virtual VDI5 terminal function selection	Same as F1.00~F1.07	0	★
E3.05	Virtual VDI terminal status set	Units digit:Virtual VDI1 Tens digit:Virtual VDI2 Hundreds digit:Virtual VDI3 Thousands digit:Virtual VDI4 Tens of thousands:Virtual VDI5	00000	☆
E3.06	Virtual VDI terminal effective status set mode	Units digit:Virtual VDI1 Tens digit:Virtual VDI2 Hundreds digit:Virtual VDI3 Thousands digit:Virtual VDI4 Tens of thousands:Virtual VDI5	11111	★
E3.07	AI1 terminal as a function selection of DI	Same as F1.00~F1.07	0	★
E3.08	AI2 terminal as a function selection of DI	Same as F1.00~F1.07	0	★
E3.09	Reserved			
E3.10	AI as DI effective mode selection	Units digit:AI1 0:High level effectively; 1:Low level effectively Tens digit:AI2(0~1,same as units digit) Hundreds digit: AI3(0~1,same as units digit)	000	★
E3.11	Virtual VDO1 output function selection	Same as F2.01~F2.05	0	☆
E3.12	Virtual VDO2 output function	Same as F2.01~F2.05	0	☆

E3.13	Virtual VDO3 output function	Same as F2.01~F2.05	0	☆
E3.14	Virtual VDO4 output function	Same as F2.01~F2.05	0	☆
E3.15	Virtual VDO5 output function	Same as F2.01~F2.05	0	☆
E3.16	VDO output terminal effective status selection	Units digit:VDO1; 0:Positive logic; 1:Negative logic Tens digit: VDO2(0~1,same as above) Hundreds digit:VDO3(0~1,same as above) Thousands digit:VDO4(0~1,same as above) Tens of thousands digit: VDO5(0~1,same as above)	00000	☆
E3.17	VDO1 output delay time	0.0s ~ 3600.0s	0.0s	☆
E3.18	VDO2 output delay time	0.0s~3600.0s	0.0s	☆
E3.19	VDO3 output delay time	0.0s~3600.0s	0.0s	☆
E3.20	VDO4 output delay time	0.0s~3600.0s	0.0s	☆
E3.21	VDO5 output delay time	0.0s~3600.0s	0.0s	☆

5-1-15.E8 group - Constant pressure water supply special group

Code	Parameter name	Setting range	Factory setting	Change
E8.00	Year	Show year	-	☆
E8.01	Month - Day	Show month and date	-	☆
E8.02	Time	Show current time	-	☆
E8.03	Second	0~60s	-	☆
Set according to the actual time. Manual setting is required for each power on. When Y0.00=1, the time parameter will not be restored. If a special touch screen is used, the time will be automatically updated				
E8.04	Unit selection	0: Mpa 1:bar 2:psi	0	
Change the settings according to the habits of units in different regions when working for the first time.				
E8.05	Pressure gauge range	0~16.00 Mpa	1.60Mpa	☆
E8.06	Pressure sensor selection channel	0:A11 2:A12	0	☆
E8.07	Start pump number	1~8	1	☆
Select the pump number that the inverter starts to run. 1 corresponds to motor A and 2 corresponds to motor B. (Note: the pump number must be the inverter motor. If this parameter is changed, the inverter will automatically set the corresponding motor as the inverter motor).				
E8.08	Low pressure alarm	0~16.00Mpa	0.05Mpa	☆
Displayed value for linkage setting of pump increase pressure (displayed value of pump increase pressure=set pressure - lower offset of pump increase pressure)				

E8.09	Ultra high pressure value display	0~16.00Mpa	0.40Mpa	☆
Set a pump increase pressure value. Only when the value is lower than this value and the frequency is higher than the upper limit frequency can the pump increase operation be carried out. If the value is higher than this value, it means that the target pressure is close to the target pressure and no pump increase is needed				
E8.10	Pump increase delay time	0~6553.5s	10.0s	☆
How long to delay the pump increase operation.				
E8.11	Transfer delay time	0~6553.5s	0.5s	☆
Delay when the frequency conversion of the same pump is switched to power frequency during pump increase.				
E8.12	Delay time of work transformation	0~6553.5s	10.0s	☆
In the process of increasing the pump, the frequency conversion operation time of the next pump shall be started after the power frequency rises.				
E8.13	Upper offset of reduced pump pressure	0~16.00Mpa	0.05Mpa	☆
Display value for linkage setting of pump increase pressure (display value of pump decrease pressure=set pressure+upper offset of pump decrease pressure)				
E8.14	Displayed value of reduced pump pressure	0~16.00Mpa	0.50Mpa	☆
E8.15	Pump reduction frequency	0.00Hz~F0.19(Maximum frequency)	30.00Hz	☆
E8.16	Pump reduction delay time	0~6553.5s	10.0s	☆
When the system works with one frequency converter+multiple power frequency pumps supplying water at the same time, when the water supply pressure is greater than the displayed value of the pump reduction pressure and the frequency is lower than the pump reduction frequency, the frequency converter will reduce the pump after the pump reduction delay time. If the pump reduction is still high after the pump reduction, the pump will continue to reduce, so as to achieve rapid regulation, which will compensate for the disadvantage of unstable pressure when the water load of the conventional water supply system changes suddenly.				
E8.17	Low voltage alarm	0~16.00Mpa	0.05Mpa	☆
If the pressure is still less than this value after the low voltage operation of the inverter for E8.18, the inverter will report ERR_46 Fault.				
E8.18	Low voltage duration	0.0s~6553.5s	500.0s	☆
E8.19	Ultra high pressure upper offset	0~16.00Mpa	0.20Mpa	☆
Used for linkage setting of ultra-high pressure display value (ultra-high pressure value display=set pressure+ultra-high pressure upper offset)				
E8.20	Display of ultra-high pressure value	0~16.00Mpa	0.65Mpa	☆
If the pressure still exceeds this value after the converter operates for an ultra-high voltage for E8.21, the converter reports ERR_47 Fault.				

E8.21	Ultra high pressure duration	0.0s~6553.5s	500.0s	☆
E8.22	Sleep function	0: Invalid 1: Valid	1	☆
<p>Select whether the hibernation function is valid or invalid.</p> <p>The graph illustrates the system's behavior during a sleep cycle. The left y-axis represents Actual pressure in Mpa, ranging from 0 to 1.6. The right y-axis represents Display frequency in Hz, ranging from 50 to 0. The x-axis represents Time in seconds. The pressure profile shows a ramp up to 1.6Mpa, a plateau at the sleep pressure display value (0.55Mpa, E8.24) for a duration of sleep delay time (E8.26), a ramp down to the wake up pressure display value (0.40Mpa, E8.28), a plateau at this level for a duration of wake up delay time (E8.30), and a final ramp up. The frequency profile shows a ramp up to the sleep frequency (25.00Hz, E8.25), a plateau during the sleep delay time (E8.26), a ramp down to the wake up frequency (30.00Hz, E8.29), a plateau during the wake up delay time (E8.30), and a final ramp up.</p>				
<p>In the absence of power frequency operation, if the pressure is greater than the sleep pressure display value and the current frequency is less than or equal to the sleep frequency (E8.25), the inverter will enter the sleep state after the sleep delay time (E8.26)</p> <p>If the pressure is less than the displayed value of wake-up pressure, and the current frequency is greater than or equal to the wake-up frequency (E8.29), after the wake-up delay time (E8.30), the frequency converter will wake up and restart.</p>				
E8.23	Sleep pressure up offset value	0~16.00Mpa	0.10Mpa	☆
<p>Used to set the display value of sleep pressure (sleep pressure display value=set pressure+sleep pressure upper offset)</p>				
E8.24	Sleep pressure display value	0~16.00Mpa	0.55Mpa	☆
E8.25	Sleep frequency	0~Maximum frequency (F0.19)	25.00Hz	☆
E8.26	Sleep Delay Time	0.0s~6500.0s	600.0s	☆
E8.27	Offset under wake-up pressure	0~16.00Mpa	0.05Mpa	☆
<p>Used for linkage setting of welcome pressure display value (wake-up pressure display value=set pressure – lower offset of wake-up pressure)</p>				
E8.28	Wake up pressure display value	0~16.00Mpa	0.40Mpa	☆
E8.29	Wake up frequency	0~Maximum frequency (F0.19)	30.00Hz	☆
E8.30	Wakeup delay time	0.0S~6500.0S	10s	☆
E8.31	Motor A Properties	0: invalid 1: frequency conversion 2: power frequency	1	★
E8.32	Motor B Properties	0: invalid 1: frequency conversion	1	★

		2: power frequency		
E8.33	Motor C Properties	0: invalid 1: frequency conversion 2: power frequency	0	★
E8.34	Motor D Properties	0: invalid 1: frequency conversion 2: power frequency	0	★
E8.35	Motor E Properties	0: invalid 1: frequency conversion 2: power frequency	0	★
E8.36	Motor F Properties	0: invalid 1: frequency conversion 2: power frequency	0	★
E8.37	Motor G Properties	0: invalid 1: frequency conversion 2: power frequency	0	★
E8.38	Motor H Properties	0: invalid 1: frequency conversion 2: power frequency	0	★
<p>During operation, 0 cannot be changed: if it is invalid, the motor will not participate in the system operation and the relay will not output; Option 1: frequency conversion, the motor frequency conversion soft starter will participate in the system operation; If 2 power frequency is selected, the motor will start directly at power frequency; The operation of the system can be flexibly set by reasonably setting the motor attributes and F2 group relay output selection.</p>				
E8.39	Start time T1	0.00~23.59	8.30	☆
E8.40	Set pressure 1	0~16.00Mpa	0.45Mpa	☆
E8.41	Start time T2	0.00~23.59	8.30	☆
E8.42	Set pressure2	0~16.00Mpa	0.45Mpa	☆
E8.43	Start time T3	0.00~23.59	8.30	☆
E8.44	Set pressure3	0~16.00Mpa	0.45Mpa	☆
E8.45	Start time T4	0.00~23.59	8.30	☆
E8.46	Set pressure4	0~16.00Mpa	0.45Mpa	☆
E8.47	Start time T5	0.00~23.59	8.30	☆
E8.48	Set pressure5	0~16.00Mpa	0.45Mpa	☆
E8.49	Start time T6	0.00~23.59	8.30	☆
E8.50	Set pressure6	0~16.00Mpa	0.45Mpa	☆
E8.51	Start time T7	0.00~23.59	8.30	☆
E8.52	Set pressure7	0~16.00Mpa	0.45Mpa	☆
E8.53	Start time T8	0.00~23.59	8.30	☆
E8.54	Set pressure8	0~16.00Mpa	0.45Mpa	☆
<p>The above parameters are used for the time segment setting of multi segment pressure water supply and the pressure setting of corresponding time segment;</p> <p>1: Time setting principle: T1<T2<T3<T4<T5<T6<T7<T8</p> <p>2: T1 refers to the period from T1 to T2, T2 refers to the period from T2 to T3, and so on. T8 refers to the period from T8 to T1</p> <p>3: If the time at the previous moment is greater than or equal to the time at the next moment, the subsequent time period is invalid. If the time at T3 is set to be greater than the time at T4, the converter operates circularly in the time period T1 ->T2 ->T3; If time T1 is greater than time T2, the converter only operates at the set pressure in time T1</p>				
E8.55	Change pump regularly	0.0min~6553.5min	480.0min	☆
<p>After the system is powered on, the pump shall be changed according to the timing. At the</p>				

same time, when the time reaches the set time and only one pump is working at the frequency conversion, the frequency conversion of the pump shall be stopped, with a delay of E8.12. When the time reaches, the next variable frequency pump shall be started. If the time is up and there is power frequency output, start timing again.				
E8.56	Faulty pump override function	0: Invalid 1: Valid	0	☆
E8.57	Number of failed pumps	0~4	2	☆
When a specific fault occurs, it can automatically bypass the fault water pump and start the next one for operation. The number of fault reset is E8.57				
E8.58	Water supply mode	0: Normal 1: Water supply mode in peak period	0	☆
0: variable frequency soft start, first start, first stop 1: direct power frequency start during pump increase operation, reducing start time				
E8.59	DI control motor start stop attribute	0: DI terminal control is valid 1: DI terminal control is invalid	0	☆
DI terminal control is valid: DI terminal signal and corresponding motor attribute of E8.31-E8.38 must be valid at the same time, and the corresponding motor start stop attribute is valid DI terminal control is invalid: only function code E8.31-E8.38 controls				
E8.60	Command source selection	0: keyboard control 4: Keyboard+terminal+communication	0	★
E8.61	Maximum frequency	50.00Hz~320.00Hz	50.00Hz	★
E8.62	Upper limit frequency	0.00Hz~F0.19(Maximum frequency)	50.00Hz	☆
E8.63	Lower limit frequency	0.00Hz~F0.21(Upper limit frequency)	20.00Hz	☆
E8.64	retain	0: Constant pressure water supply mode 1: Standard mode	0	★
E8.65	retain	Relay disconnection delay time after sleep	0.5	☆
E8.66	retain	Advance pick-up time of relay before wake-up	0.5	☆
E8.67	Proportional gain Kp1	0.0~200.0	50.0	☆
E8.68	Integration time Ti1	0.1~10.0s	1.0s	☆
E8.69	Differential time Td1	0.000~10.000S	0.001s	☆

5-1-16.b0 group - Motor parameters

Code	Parameter name	Setting range	Factory setting	Change
b0.00	Motor type selection	0: Normal asynchronous motor 1: Asynchronous variable frequency motor	0	★
b0.01	Rated power	0.1~1000.0kW	Model determination	★

b0.02	Rated voltage	1~2000V	Model determination	★
b0.03	Rated current	0.01A~655.35A(Inverter power≤55kW) 0.1A~6553.5A(Inverter power>55kW)	Model determination	★
b0.04	Rated frequency	0.01Hz~F0.19(Maximum frequency)	Model determination	★
b0.05	Rated speed	1rpm~36000rpm	Model determination	★
b0.06	Asynchronous stator resistance	0.001Ω~65.535Ω(Inverter power≤55kW) 0.0001Ω~6.5535Ω(Inverter power >55kW)	Motor parameters	★
b0.07	Asynchronous rotor resistance	0.001Ω~65.535Ω(Inverter power≤55kW) 0.0001Ω~6.5535Ω(Inverter power >55kW)	Motor parameters	★
b0.08	Asynchronous leakage	0.01mH~655.35mH(Inverter power≤55kW) 0.001mH~65.535mH(Inverter power >55kW)	Motor parameters	★
b0.09	Asynchronous mutual inductance	0.1mH~6553.5mH(Inverter power≤55kW) 0.01mH~655.35mH(Inverter power >55kW)	Motor parameters	★
b0.10	Asynchronous no-load current	0.01A~b0.03(Inverter power≤55kW) 0.1A~b0.03(Inverter power >55kW)	Motor parameters	★
b0.27	Motor parameter auto tuning	0: No operation 11: Synchronous motor parameters still auto tuning 12: Synchronous motor parameters comprehensive auto tuning	0	★

5-1-17.y0 group - Function code management

Code	Parameter name	Setting range	Factory setting	Change
y0.00	Parameter initialization	0: No operation 1: Restore default parameter values, not including motor parameters 2: Clear history 3: Restore default parameter values, including motor parameters 4: Backup current user parameters 501: Restore from backup user parameters 10: Clear keyboard storage area3 11: Upload parameter to keyboard storage area 1 12: Upload parameter to keyboard storage area 2 21: Download the parameters from keyboard storage 1 area to the storage system 3 22: download the parameters from keyboard storage 2 area to the storage system 3	0	★
y0.01	User password	0~65535	0	☆
y0.02	Function parameter group display selection	Units digit: d group display selection 0: Not displays 1: Displays	11111	★

		Tens digit: E group display selection(the same above) Hundreds digit:b group display selection(the same above) Thousands digit:y group display selection(the same above) Tens thousands digit:L group display selection(the same above)		
y0.03	Personality parameter group display selection	Units digit:User's customization parameter display selection 0:Not display 1:Display Tens digit :User's change parameter display selection 0:Not display 1:Display	00	☆
y0.04	Function code modification properties	0: Modifiable 1: Not modifiable	0	☆

5-1-18.y1 group - Fault inquiry

Code	Parameter name	Setting range	Factory setting	Change
y1.00	Type of the first fault	0: No fault	-	●
y1.01	Type of the second fault	1: Inverter unit protection 2: Acceleration overcurrent 3: Deceleration overcurrent	-	●
y1.02	Type of the third(at last) fault	4: Constant speed overcurrent 5: Acceleration overvoltage 6: Deceleration overvoltage 7: Constant speed overvoltage 8: Control power failure 9: Undervoltage 10: Inverter overload 11: Motor Overload 12: Input phase loss 13: Output phase loss 14: Module overheating 15: External fault 16: Communication abnormal 17: Contactor abnormal 18: Current detection abnormal 19: Motor self-learning abnormal 21: Parameter read and write abnormal 22: Inverter hardware abnormal 23: Motor short to ground 24: Reserved 25: Reserved 26: Running time arrival 27: Custom fault 1 28: Custom fault 2 29: Power-on time arrival 30: Offload 31: PID feedback loss when running 40: Fast current limiting timeout 46: Low pressure alarm 47: High pressure alarm 49: Relay error 51: Initial position error COF: Communication failure	-	●
y1.03	Frequency of the third(at last) fault	-	-	●
y1.04	Current of the third(at last) fault	-	-	●
y1.05	Bus voltage of the third(at last) fault	-	-	●
y1.06	Input terminal status of the third(at last) fault	-	-	●
y1.07	Output terminal status of the third(at last) fault	-	-	●
y1.08	Reserved			

y1.09	Power-on time of the third(at last) fault	-	-	●
y1.10	Running time of the third(at last) fault	-	-	●
y1.11	Pressure at the third failure	-	-	●
y1.12	Third failure time	-	-	●
y1.13	Frequency of the second fault	-	-	●
y1.14	Current of the second fault	-	-	●
y1.15	Bus voltage of the second fault	-	-	●
y1.16	Input terminal status of the second fault	-	-	●
y1.17	Output terminal status of the second fault	-	-	●
y1.18	Reserved			
y1.19	Power-on time of the second fault	-	-	●
y1.20	Running time of the second fault	-	-	●
y1.21	Pressure at the second failure	-	-	●
y1.22	Second failure time	-	-	●
y1.23	Frequency of the first fault	-	-	●
y1.24	Current of the first fault	-	-	●
y1.25	Bus voltage of the first fault	-	-	●
y1.26	Input terminal status of the first fault	-	-	●
y1.27	Output terminal status of the first fault	-	-	●
y1.28	Reserved			
y1.29	Power-on time of the first fault	-	-	●
y1.30	Running time of the first fault	-	-	●
y1.31	Pressure at the first failure	-	-	●
y1.32	First failure time	-	-	●

Chapter 6 Troubleshooting

6-1.Fault alarm and countermeasures

PI500-W can provide effective protection when the equipment performance is played fully. In case of abnormal fault, the protection function will be invoked, the inverter will stop output, and the faulty relay contact of the inverter will start, and the fault code will be displayed on the display panel of the inverter. Before consulting the service department, user can perform self-check , analyze the fault cause and find out the solution according to the instructions of this chapter. If the fault is caused by the reasons as described in the dotted frame, please consult the agents of inverter or directly contact with our company.

No.	Fault ID	Failure type	Possible causes	Solutions
1	Err.01	Inverter unit protection	<ol style="list-style-type: none"> 1.The short circuit of inverter output happens 2.The wiring for the motor and the inverter is too long 3.Module overheating 4.The internal wiring of inverter is loose 5.The main control panel is abnormal 6.The drive panel is abnormal. 7.The inverter module is abnormal 	<ol style="list-style-type: none"> 1.Eliminate peripheral faults 2.Additionally install the reactor or the output filter 3.Check the air duct is blocked or not and the fan is working normally or not, and eliminate problems 4.Correctly plug all cables 5.Seek for technical support
2	Err.02	Acceleration over current	<ol style="list-style-type: none"> 1.The acceleration time is too short 2.Manual torque boost or V/F curve is not suitable 3.The voltage is low 4.The short-circuit or earthing of inverter output happens 5.The control mode is vector and without identification of parameters 6.The motor that is rotating is started unexpectedly. 7.Suddenly increase the load in the process of acceleration. 8.The type selection of inverter is small 	<ol style="list-style-type: none"> 1.Increase acceleration time 2.Adjust manual torque boost or V/F curve 3.Set the voltage to the normal range 4.Eliminate peripheral faults 5.perform identification for the motor parameters 6.Select Speed Tracking Start or restart after stopping the motor. 7.Cancel the sudden load 8.Choose the inverter with large power level
3	Err.03	Deceleration over current	<ol style="list-style-type: none"> 1.The short-circuit or earthing of inverter output happens 2.The control mode is vector and without identification of parameters 3.The deceleration time is too short 4.The voltage is low 5.Suddenly increase the load in the process of deceleration. 6.Didn't install braking unit and braking resistor 	<ol style="list-style-type: none"> 1.Eliminate peripheral faults 2.Perform identification for the motor parameters 3.Increase the deceleration time 4.Set the voltage to the normal range 5.Cancel the sudden load 6.Install braking unit and brake resistor

4	Err.04	Constant speed over current	<ol style="list-style-type: none"> 1.The short-circuit or earthing of inverter output happens 2.The control mode is vector and without identification of parameters 3.The voltage is low 4.whether suddenly increase the load when running 5.The type selection of inverter is small 	<ol style="list-style-type: none"> 1.Eliminate peripheral faults 2.perform identification for the motor parameters 3.Set the voltage to the normal range 4.Cancel the sudden load 5.Choose the inverter with large power level
5	Err.05	Acceleration over voltage	<ol style="list-style-type: none"> 1.Didn't install braking unit and braking resistor 2.The input voltage is high 3.There is external force to drag the motor to run when accelerating. 4.The acceleration time is too short 	<ol style="list-style-type: none"> 1.Install braking unit and brake resistor 2.Set the voltage to the normal range 3.Cancel the external force or install braking resistor. 4.Increase acceleration time
6	Err.06	Deceleration over voltage	<ol style="list-style-type: none"> 1.The input voltage is high 2.There is external force to drag the motor to run when decelerating. 3.The deceleration time is too short 4.Didn't install braking unit and braking resistor 	<ol style="list-style-type: none"> 1.Set the voltage to the normal range 2.Cancel the external force or install braking resistor. 3.Increase the deceleration time 4.Install braking unit and brake resistor
7	Err.07	Constant Speed Over voltage	<ol style="list-style-type: none"> 1.There is external force to drag the motor to run when running 2.The input voltage is high 	<ol style="list-style-type: none"> 1.Cancel the external force or install braking resistor. 2.Set the voltage to the normal range
8	Err.08	Control power failure	<ol style="list-style-type: none"> 1.The range of input voltage is not within the specification 2. Frequent under voltage failures 	Adjust the voltage to the range of the requirements of specification
9	Err.09	Under voltage fault	<ol style="list-style-type: none"> 1.The momentary power cut 2.The inverter's input voltage is not within the specification 3.The bus voltage is not normal 4.The rectifier bridge and buffer resistance are abnormal 5.The drive panel is abnormal. 6.The control panel is abnormal 	<ol style="list-style-type: none"> 1.Reset fault 2.Adjust the voltage to the normal range 3.Seek for technical support
10	Err.10	Inverter overload	<ol style="list-style-type: none"> 1.The type selection of inverter is small 2.Whether the load is too large or the motor stall occurs 	<ol style="list-style-type: none"> 1.Choose the inverter with large power level 2.Reduce the load and check the motor and its mechanical conditions
11	Err.11	Motor overload	<ol style="list-style-type: none"> 1. Power grid voltage is too low 2.Whether the setting motor protection parameters (f8.03) is appropriate or not 3.Whether the load is too large or the motor stall occurs 	<ol style="list-style-type: none"> 1.Check the power grid voltage 2.Correctly set this parameter. 3.Reduce the load and check the motor and its mechanical conditions

12	Err.12	Input phase loss	<ol style="list-style-type: none"> 1.The drive panel is abnormal. 2.The lightning protection plate is abnormal 3.The main control panel is abnormal 4.The three-phase input power is not normal 	<ol style="list-style-type: none"> 1.Replace the drive, the power board or contactor 2.Seek for technical support 3.Check and eliminate the existing problems in the peripheral line
13	Err.13	Output phase loss	<ol style="list-style-type: none"> 1.The lead wires from the inverter to the motor is not normal 2.The inverter's three phase output is unbalanced when the motor is running 3.The drive panel is abnormal. 4.The module is abnormal 	<ol style="list-style-type: none"> 1.Eliminate peripheral faults 2.Check the motor's three-phase winding is normal or not and eliminate faults 3.Seek for technical support
14	Err.14	Module overheating	<ol style="list-style-type: none"> 1.The air duct is blocked 2.The fan is damaged 3.The ambient temperature is too high 4.The module thermistor is damaged 5.The inverter module is damaged 	<ol style="list-style-type: none"> 1.Clean up the air duct 2.Replace the fan 3.Decrease the ambient temperature 4.Replace the thermistor 5.Replace the inverter module
15	Err.15	External equipment fault	Input external fault signal through the multi-function terminal DI	Reset run
16	Err.16	Communication fault	<ol style="list-style-type: none"> 1.The communication cable is not normal 2.The settings for communication expansion card F9.07 are incorrect 3.The settings for communication parameters F9 group are incorrect 4.The host computer is not working properly 	<ol style="list-style-type: none"> 1.Check the communication cable 2.Correctly set the communications expansion card type 3.Correctly set the communication parameters 4.Check the wiring of host computer
17	Err.17	Contacting fault	<ol style="list-style-type: none"> 1.Input phase loss 2.The drive plate and the contact are not normal 	<ol style="list-style-type: none"> 1.Check and eliminate the existing problems in the peripheral line 2.Replace the drive, the power board or contactor
18	Err.18	Current detection fault	<ol style="list-style-type: none"> 1.Check Hall device 2.The drive panel is abnormal. 	<ol style="list-style-type: none"> 1.Replace the drive panel 2.Replace hall device
19	Err.19	Motor parameter auto tuning fault	<ol style="list-style-type: none"> 1.The motor parameters was not set according to the nameplate 2.The identification process of parameter is timeout 	<ol style="list-style-type: none"> 1.Correctly set motor parameter according to the nameplate 2.Check the lead wire from the inverter to the motor
21	Err.21	EEPROM read and write fault	EEPROM chip is damaged	Replace the main control panel
22	Err.22	Inverter hardware fault	<ol style="list-style-type: none"> 1.Over voltage 2.Over current 	<ol style="list-style-type: none"> 1.Eliminate over voltage fault 2.Eliminate over current fault
23	Err.23	Short-circuit to ground fault	Motor short to ground	Replace the cable or motor

26	Err.26	Cumulative running time arrival fault	Cumulative running time arrival fault	Clear history information by using initialization function parameters
27	Err.27	Custom fault 1	Input custom fault 1 signal through the multi-function terminal DI	Reset run
28	Err.28	Custom fault 2	Input custom fault 2 signal through the multi-function terminal DI	Reset run
29	Err.29	Total power-on time arrival fault	Total power-on time reaches the set value	Clear history information by using initialization function parameters
31	Err.31	PID feedback loss when running fault	PID feedback is less than the set value of E2.11	Check PID feedback signal or set E2.11 to an appropriate value
40	Err.40	Quick current limiting fault	1. Whether the load is too large or the motor stall occurs 2. The type selection of inverter is small	1. Reduce the load and check the motor and its mechanical conditions 2. Choose the inverter with large power level
46	Err.46	Low pressure alarm	Feed back pressure in constant pressure water supply mode is lower than the set low pressure alarm pressure value	1. Reasonably set the low pressure alarm pressure value according to the actual situation 2. Check if the actual pressure is too low
47	Err.47	Ultra high pressure alarm	Constant pressure water supply mode feedback pressure is higher than the set ultra-high pressure alarm pressure value	1. Reasonably set the ultra-high pressure alarm pressure value according to the actual situation 2. Detect if the actual pressure is too high
48	Err.48	Too many faulty pumps	In the constant pressure water supply mode, when the faulty pump bypass function is valid, the number of faulty pumps bypassed is more than the set number of faulty pumps.	1. Reasonably set the number of E8.57 faulty pumps 2. Check the fault cause of the faulty pump and reset the fault
49	Err.49	relay error	The effective number of frequency conversion switching relays in constant pressure water supply mode is more than 1, or the frequency conversion switching relay and power frequency switching relay of a single pump are valid at the same time	Check whether all relays on the control board are abnormal
51	Err.51	Initial position error	The deviation between the motor parameters and the actual parameters is too large	Reconfirm the correct motor parameters, focus on whether the rated current is set to too small.
70	Err.70	No DI input	In the automatic control mode of constant pressure water supply mode, the user selects E8.59=0,	1. Check the F1.00-F1.05 DI terminal function selection 2. Check whether the motor

			the DI terminal controls the motor start and stop attribute is valid, and there is no correct DI signal input when running the inverter	startup attributes corresponding to E8.31-E8.38 are selected correctly 3. At least one DI signal must be valid before running
-	COF	Communication failure	1.Keyboard interface control board interface; 2.Keyboard or crystal connector; 3.Control board or keyboard hardware damage; 4.Keyboard line is too long, causing the interference.	1.Detection of keyboard interface, control board interface is abnormal. 2.Detect keyboard, crystal joints are abnormal. 3.Replace control board or keyboard. 4. Consult factory, seek help.

6-2.EMC (Electromagnetic compatibility)

6-2-1.Definition

Electromagnetic compatibility refers to the ability that the electric equipment runs in an electromagnetic interference environment and implements its function stably without interferences on the electromagnetic environment.

6-2-2.EMC standard

In accordance with the requirements of the Chinese national standard GB 12668.3-2012/IEC 61800-3:2005, the inverter must comply with the requirements of electromagnetic interference and anti- electromagnetic interference.

Our existing products adopt the latest international standards: IEC/EN61800-3: 2004 (Adjustable speed electrical Power drive systems Part 3: EMC requirements and specific test methods), which is equivalent to the Chinese national standards GB 12668.3-2012/IEC 61800-3:2004. EC/EN61800-3 assesses the inverter in terms of electromagnetic interference and anti-electronic interference. Electromagnetic interference mainly tests the radiation interference, conduction interference and harmonics interference on the inverter (necessary for civil inverter).

Anti-electromagnetic interference mainly tests the conduction immunity, radiation immunity, surge immunity, EFTB(Electrical Fast Transient Burs) immunity, ESD immunity and power low frequency end immunity (the specific test items includes: 1. Immunity tests of input voltage sag, interrupt and change; 2.Commutation notch immunity; 3. harmonic input immunity ; 4. input frequency change; 5. input voltage unbalance; 6. input voltage fluctuation). The tests shall be conducted strictly in accordance with the above requirements of IEC/EN61800-3, and our products are installed and used according to the guideline of the Section 6-3 and can provide good electromagnetic compatibility in general industry environment.

6-3.EMC directive

6-3-1.Harmonic effect

The higher harmonics of power supply may damage the inverter. Thus, at some places where the quality of power system is relatively poor, it is recommended to install AC input reactor.

6-3-2.Electromagnetic interference and installation precautions

There are two kinds of electromagnetic interference, one is the interference from electromagnetic noise in the surrounding environment to the inverter, and the other is the interference from the inverter to the surrounding equipment.

Installation Precautions:

- 1)The earth wires of the Inverter and other electric products ca shall be well grounded;
- 2)The power cables of the inverter power input and output and the cable of weak current signal (e.g. control line) shall not be arranged in parallel but in vertical if possible.
- 3) It is recommended that the output power cables of the inverter shall use shield cables or steel pipe shielded cables and that the shielding layer shall be grounded reliably, the lead cables of the equipment suffering interferences shall use twisted-pair shielded control cables, and the

shielding layer shall be grounded reliably.

4) When the length of motor cable is longer than 50 meters, it needs to install output filter or reactor.

6-3-3. Remedies for the interference from the surrounding electromagnetic equipment to the inverter

Generally the electromagnetic interference on the inverter is generated by plenty of relays, contactors and electromagnetic brakes installed near the inverter. When the inverter has error action due to the interference, the following measures is recommended:

- 1) Install surge suppressor on the devices generating interference;
- 2) Install filter at the input end of the inverter, please refer to Section 6.3.6 for the specific operations.
- 3) The lead cables of the control signal cable of the inverter and the detection line shall use the shielded cable and the shielding layer shall be grounded reliably.

6-3-4. Remedies for the interference from the inverter to the surrounding electromagnetic equipment

These noise interference are classified into two types: one is the radiation interference of the inverter, and the other is the conduction interference of the inverter. These two types of interference cause that the surrounding electric equipment suffer from the affect of electromagnetic or electrostatic induction. Further, the surrounding equipment produces error action. For different interference, please refer to the following remedies:

- 1) Generally the meters, receivers and sensors for measuring and testing have more weak signals. If they are placed nearby the inverter or together with the inverter in the same control cabinet, they easily suffer from interference and thus generate error actions. It is recommended to handle with the following methods: away from the interference source as far as possible; do not arrange the signal cables with the power cables in parallel and never bind them together; both the signal cables and power cables shall use shielded cables and shall be well grounded; install ferrite magnetic ring (with suppressing frequency of 30 to 1, 000MHz) at the output side of the inverter and wind it 2 to 3 turns; install EMC output filter in more severe conditions.
- 2) When the interfered equipment and the inverter use the same power supply, it may cause conduction interference. If the above methods cannot remove the interference, it shall install EMC filter between the inverter and the power supply (refer to Section 6.3.6 for the selection operation);
- 3) The surrounding equipment shall be separately grounded, which can avoid the interference caused by the leakage current of the inverter's grounding wire when common grounding mode is adopted.

6-3-5. Remedies for leakage current

There are two forms of leakage current when using the inverter. One is leakage current to the earth, and the other is leakage current between the cables.

- 1) Factors of affecting leakage current to the earth and its solutions:

There are the distributed capacitance between the lead cables and the earth. The larger the distributed capacitance, the larger the leakage current; the distributed capacitance can be reduced by effectively reducing the distance

between the inverter and the motor. The higher the carrier frequency, the larger the leakage current. The leakage current can be reduced by reducing the carrier frequency. However, the carrier frequency reduced may result in

the increase of motor noise. Please note that additional installation of reactor is also an effective method to solve leakage current problem.

The leakage current may increase with the increase of circuit current. Therefore, when the motor power is higher, the corresponding leakage current will be higher too.

- 2) Factors of producing leakage current between the cables and its solutions:

There is the distributed capacitance between the output cables of the inverter. If the current passing lines has higher harmonic, it may cause resonance and thus result in leakage current. If the thermal relay is used, it may generate error action.

The solution is to reduce the carrier frequency or install output reactor. It is recommended that

the thermal relay shall not be installed in the front of the motor when using the inverter, and that electronic over current protection function of the inverter shall be used instead.

6-3-6. Precautions on installing EMC input filter at the input end of power supply

1) Note: when using the inverter, please follow its rated values strictly. Since the filter belongs to Classification I electric appliances, the metal enclosure of the filter and the metal ground of the installing cabinet shall be well earthed in a large area, and have good conduction continuity, otherwise there may be danger of electric shock and the EMC effect may be greatly affected. Through the EMC test, it is found that the filter ground end and the PE end of the inverter must be connected to the same public earth end, otherwise the EMC effect may be greatly affected.

2) The filter shall be installed at a place close to the input end of the power supply as much as possible.

Chapter 7 Dimension

7-1.Dimension

7-1-1.Product outside drawing, installation size upper cover plate

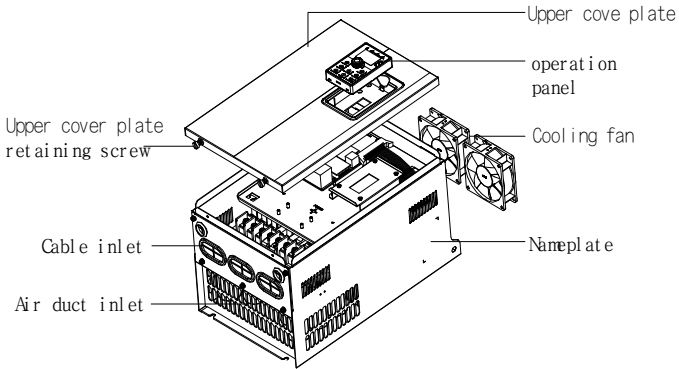
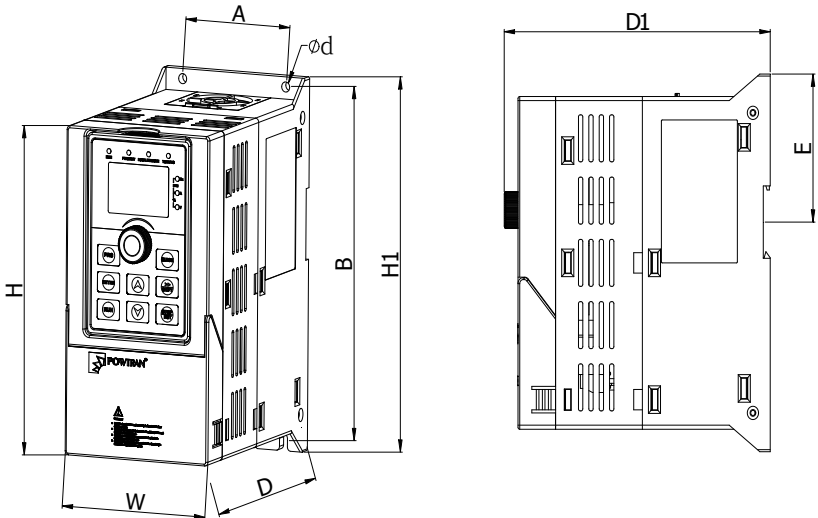

Figure 7-1: 30kW G3 and above power product outside drawing, installation dimension

7-1-2.PI500-W series



Note: 0.75~4 kW G3 support DIN-rail mounting

Figure 7-2: 0.75~4kW Dimension

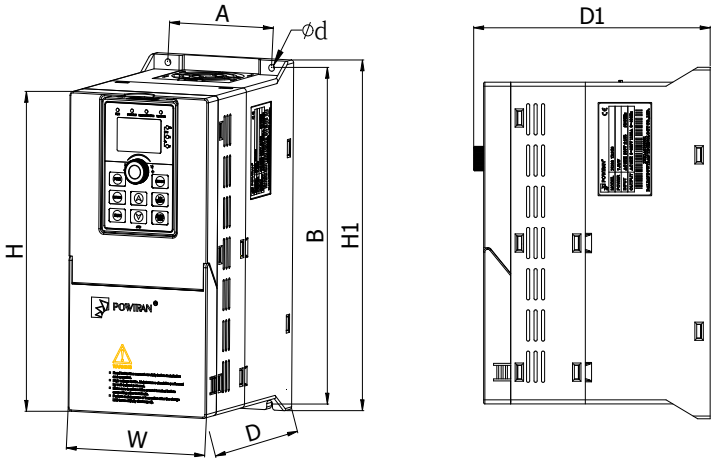

Figuer 7-3: 5.5~11kW G3 Dimension

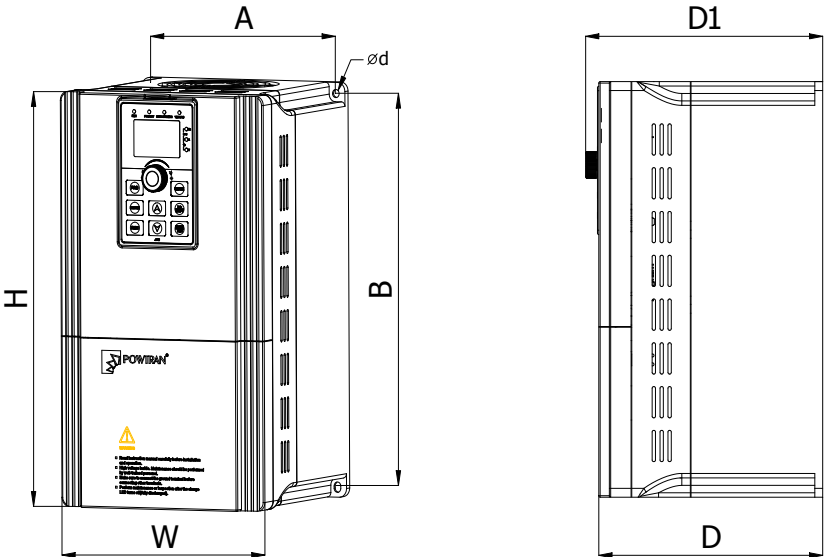

Figuer 7-4: 15 ~ 22kW G3 Dimension

7-1-2-1. Plastic shell series:

1) Outline dimension drawing and installation dimension of single phase 220 V AC

Model	Output power (kW)	Dimension (mm)					Installation (mm)			Guide rail installation position	Weight (kg)
		H	H1	W	D	D1	A	B	d	E	
PI500-W 0R4G1	0.4	163	185	90	146	154	65	174	5	72.5	1.6
PI500-W 0R7G1	0.75										
PI500-W 1R5G1	1.5										
PI500-W 2R2G1	2.2	163	185	90	166	174	65	174	5	72.5	1.8
PI500-W 004G1	4	238	260	120	182	190	90	250	5	/	2.7
PI500-W 5R5G1	5.5	290	/	170	193	201	155	276	5	/	5.8
PI500-W 7R5G1	7.5										

2) Outline dimension drawing and installation dimension of three phase 220 V AC

Model	Output power (kW)	Dimension (mm)					Installation (mm)			Guide rail installation position	Weight (kg)
		H	H1	W	D	D1	A	B	d	E	
PI500-W 0R4G2	0.4	163	185	90	146	154	65	174	5	72.5	1.6
PI500-W 0R7G2	0.75										
PI500-W 1R5G2	1.5										
PI500-W 2R2G2	2.2	163	185	90	166	174	65	174	5	72.5	1.8
PI500-W 004G2	4	238	260	120	182	190	90	250	5	/	2.7
PI500-W 5R5G2	5.5										
PI500-W 7R5G2	7.5	290	/	170	193	201	155	276	5	/	5.8
PI500-W 011G2	11										

3) Three phase 380V AC outline dimension drawing and installation dimension

Model	Output power (kW)	Dimension (mm)					Installation (mm)			Guide rail installation position	Weight (kg)
		H	H1	W	D	D1	A	B	d	E	
PI500-W 0R7G3	0.75	163	185	90	146	154	65	174	5	72.5	1.6
PI500-W 1R5G3	1.5										
PI500-W 2R2G3	2.2										

Chapter 7 Dimension

Model	Output power (kW)	Dimension (mm)					Installation (mm)			Guide rail installation position	Weight (kg)
		H	H1	W	D	D1	A	B	d	E	
PI500-W 004G3	4	163	185	90	166	174	65	174	5	72.5	1.8
PI500-W 5R5G3	5.5	238	260	120	182	190	90	250	5	/	2.7
PI500-W 7R5G3	7.5										
PI500-W 011F3	11										
PI500-W 011G3	11	290	/	170	193	201	155	276	5	/	5.8
PI500-W 015F3	15										
PI500-W 015G3/018F3	15/18.5										
PI500-W 018G3/022F3	18.5/22										
PI500-W 022G3	22										

4) Three phase 480v AC outline dimension drawing and installation dimension

Model	Output power (kW)	Dimension (mm)					Installation (mm)			Guide rail installation position	Weight (kg)
		H	H1	W	D	D1	A	B	d	E	
PI500-W 0R7G4	0.75	163	185	90	146	154	65	174	5	72.5	1.6
PI500-W 1R5G4	1.5										
PI500-W 2R2G4	2.2										
PI500-W 004G4	4	163	185	90	166	174	65	174	5	72.5	1.8
PI500-W 5R5G4	5.5	238	260	120	182	190	90	250	5	/	2.7
PI500-W 7R5G4	7.5										
PI500-W 011G4	11										
PI500-W 011F4	11	290	/	170	193	201	155	276	5	/	5.8
PI500-W 015F4	15										
PI500-W 015G4/018F4	15/18.5										
PI500-W 018G4/022F4	18.5/22										
PI500-W 022G4	22										

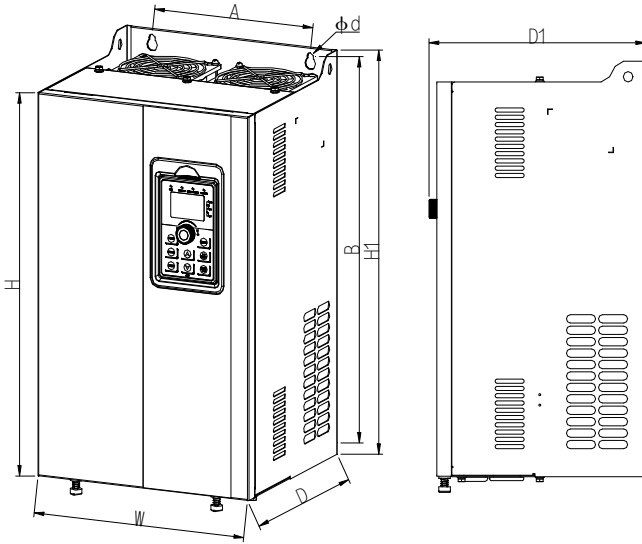

Figuer 7-5: 15~220kW G3 dimension

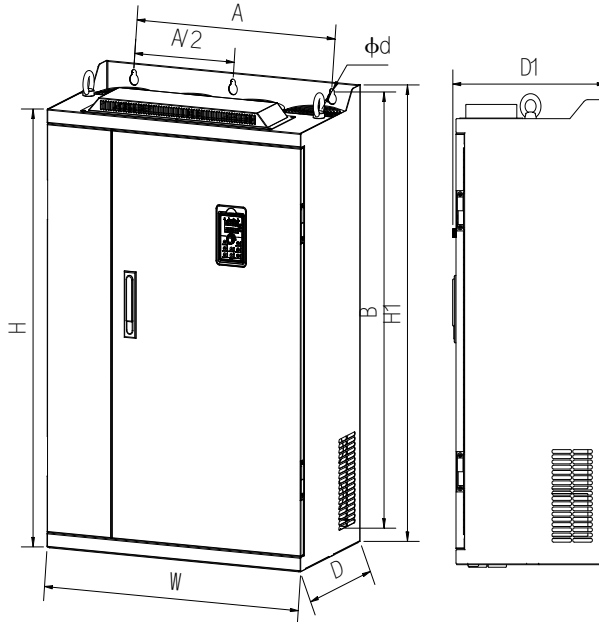

Figuer 7-6: 250~400kW G3 dimension

7-1-2-2. Iron shell wall hanging series:

1). Outline dimension drawing and installation dimension of single phase 220 V AC

Model	Output power (kW)	Dimension (mm)					Installation (mm)			Weight (kg)
		H	H1	W	D	D1	A	B	d	
PI500-W 011G1	11	330	350	210	190	198	150	335	6	9.5

2). Outline dimension drawing and installation dimension of three phase 220 V AC

Model	Output power (kW)	Dimension (mm)					Installation (mm)			Weight (kg)
		H	H1	W	D	D1	A	B	d	
PI500-W 015G2	15	380	400	240	215	223	180	385	7	13
PI500-W 018G2	18.5									
PI500-W 022G2	22	500	520	300	275	283	220	500	10	42
PI500-W 030G2	30									
PI500-W 037G2	37									
PI500-W 045G2	45	550	575	355	320	328	250	555	10	58
PI500-W 055G2	55									
PI500-W 075G2	75	695	720	400	360	368	300	700	10	73
PI500-W 093G2	93	790	820	480	390	398	370	800	11	108
PI500-W 110G2	110									
PI500-W 132G2	132	940	980	705	410	418	550	945	13	190
PI500-W 160G2	160									

3). Three phase 380V AC outline dimension drawing and installation dimension

Model	Output power (kW)	Dimension (mm)					Installation (mm)			Weight (kg)
		H	H1	W	D	D1	A	B	d	
PI500-W 030F3	30	330	350	210	190	198	150	335	6	9.5
PI500-W 030G3	30									
PI500-W 037F3	37	380	400	240	215	223	180	385	7	13
PI500-W 037G3/045F3	37/45									
PI500-W 045G3	45	380	400	280	215	223	180	385	7	14
PI500-W 055F3	55	500	520	300	275	283	220	500	10	42
PI500-W 055G3	55									
PI500-W 075F3	75									
PI500-W 075G3	75									

Model	Output power (kW)	Dimension (mm)					Installation (mm)			Weight (kg)
		H	HI	W	D	DI	A	B	d	
PI500-W 093F3	93	550	575	355	320	328	250	555	10	58
PI500-W 093G3/110F3	93/110									
PI500-W 110G3/132F3	110/132									
PI500-W 132G3	132									
PI500-W 160F3	160	695	720	400	360	368	300	700	10	73
PI500-W 160G3/187F3	160/187	790	820	480	390	398	370	800	11	108
PI500-W 187G3/200F3	187/200									
PI500-W 200G3/220F3	200/220									
PI500-W 220G3	220									
PI500-W 250F3	250	940	980	560	410	418	415	945	13	153
PI500-W 250G3/280F3	250/280									
PI500-W 280G3	280									
PI500-W 315F3	315									
PI500-W 315G3/355F3	315/355	940	980	705	410	418	550	945	13	190
PI500-W 355G3/400F3	355/400									
PI500-W 400G3	400									

4). Three phase 480V AC outline dimension drawing and installation dimension

Model	Output power (kW)	Dimension (mm)					Installation (mm)			Weight (kg)
		H	HI	W	D	DI	A	B	d	
PI500-W 030F4	30	330	350	210	190	198	150	335	6	9.5
PI500-W 030G4	30									
PI500-W 037F4	37	380	400	240	215	223	180	385	7	13
PI500-W 037G4/045F4	37/45									
PI500-W 045G4	45	380	400	280	215	223	180	385	7	14
PI500-W 055F4	55	500	520	300	275	283	220	500	10	42
PI500-W 055G4	55									
PI500-W 075F4	75									
PI500-W 075G4	75									
PI500-W 093F4	93	550	575	355	320	328	250	555	10	58
PI500-W 093G4/110F4	93/110									
PI500-W 110G4/132F4	110/132									
PI500-W 132G4	132									

Model	Output power (kW)	Dimension (mm)					Installation (mm)			Weight (kg)
		H	HI	W	D	DI	A	B	d	
PI500-W 160F4	160	695	720	400	360	368	300	700	10	73
PI500-W 160G4/187F4	160/187	790	820	480	390	398	370	800	11	108
PI500-W 187G4/200F4	187/200									
PI500-W 200G4/220F4	200/220									
PI500-W 220G4	220									
PI500-W 250F4	250	940	980	560	410	418	415	945	13	153
PI500-W 250G4/280F4	250/280									
PI500-W 280G4	280									
PI500-W 315F4	315	940	980	705	410	418	550	945	13	190
PI500-W 315G4/355F4	315/355									
PI500-W 355G4/400F4	355/400									
PI500-W 400G4	400									

7-1-3.PI500-W series(With DC reactor and base)

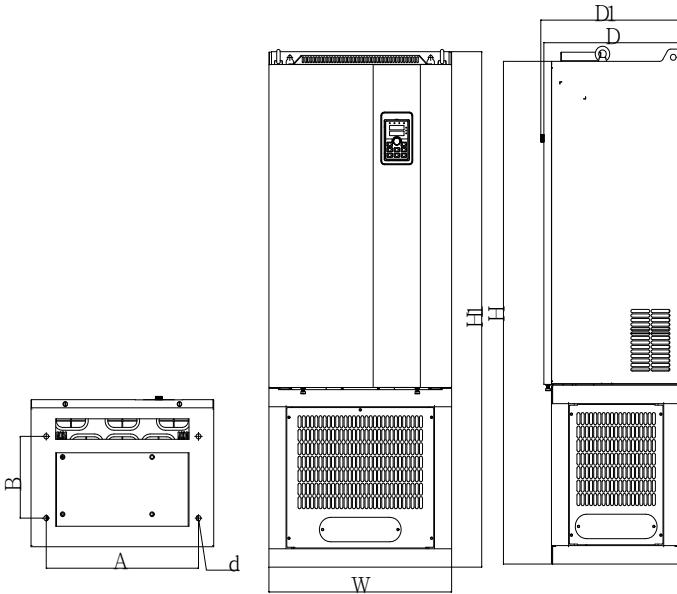

Figure 7-7: 132~220kW G3 (With DC reactor and base)Dimension

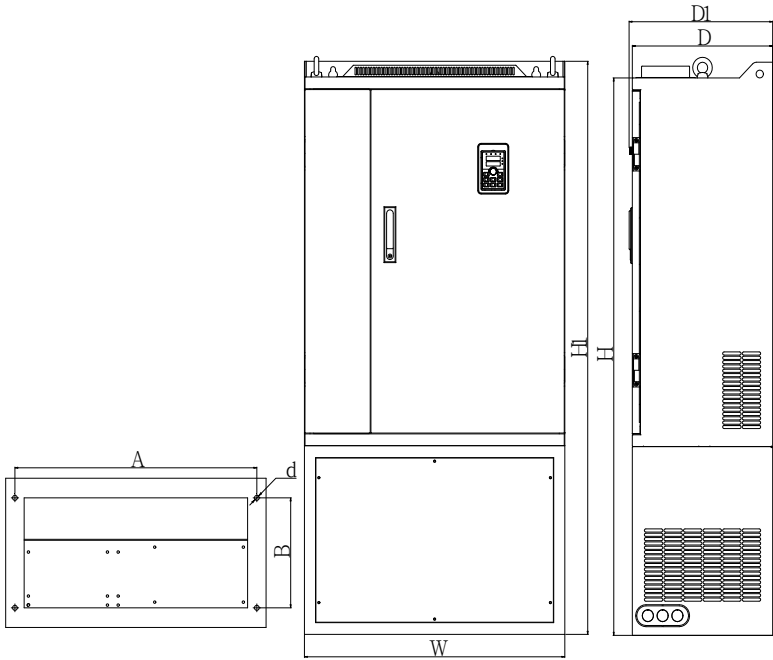

Figure 7-8: 250~400kW G3 (With DC reactor and base)Dimension

7-1-4. Iron shell floor mounted series

Outline dimension drawing and installation dimension of three phase 380V AC & three phase 480V AC

Model	Output power (kW)	Dimension (mm)					Installation (mm)			Weight (kg)
		H	H1	W	D	D1	A	B	d	
PI500-W 132G3R/160F3R	132/160	1230	1260	480	390	398	400	200	13	153
PI500-W 132G4R/160F4R										
PI500-W 160G3R/187F3R										
PI500-W 187G3R/200F3R										
PI500-W 200G3R/220F3R										
PI500-W 220G3R										
PI500-W 160G4R/187F4R										
PI500-W 187G4R/200F4R										
PI500-W 200G4R/220F4R										
PI500-W 220G4R										

PI500-W 250F3R	250	1419	1460	560	410	418	500	310	13	205
PI500-W 250G3R/280F3R	250/280									
PI500-W 280G3R	280									
PI500-W 250F4R	250									
PI500-W 250G4R/280F4R	250/280									
PI500-W 280G4R	280	1419	1460	705	410	418	645	310	13	249.4
PI500-W 315F3R	315									
PI500-W 315G3R/355F3R	315/355									
PI500-W 355G3R/400F3R	355/400									
PI500-W 400G3R	400									
PI500-W 315F4R	315									
PI500-W 315G4R/355F4R	315/355									
PI500-W 355G4R/400F4R	355/400									
PI500-W 400G4R	400									

Note: The letter "R" indicates that there is a DC reactor; the height dimension of the product after installing the suspension ring screw is: H1 + 15mm.

7-1-5.Keyboard Size Diagram

PI500-W Keyboard Size Diagram:

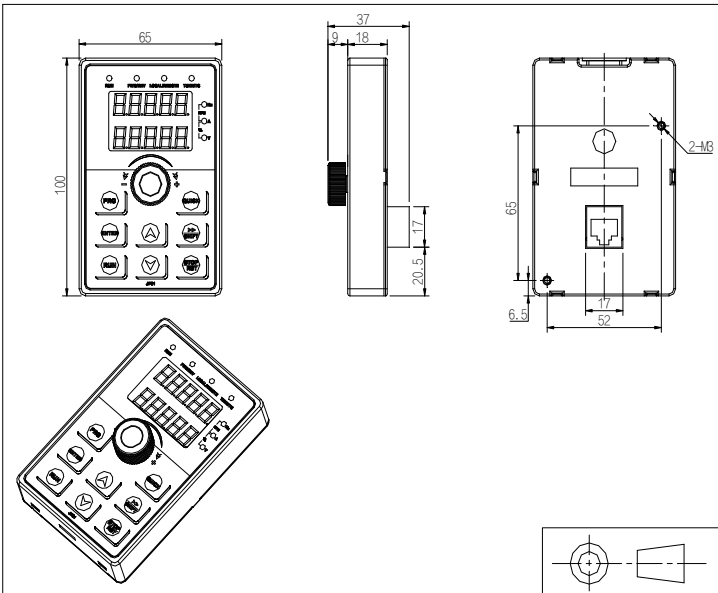

Figure 7-9: PI500-W Keyboard Size

PI500-W Keyboard Warehouse Size Diagram:

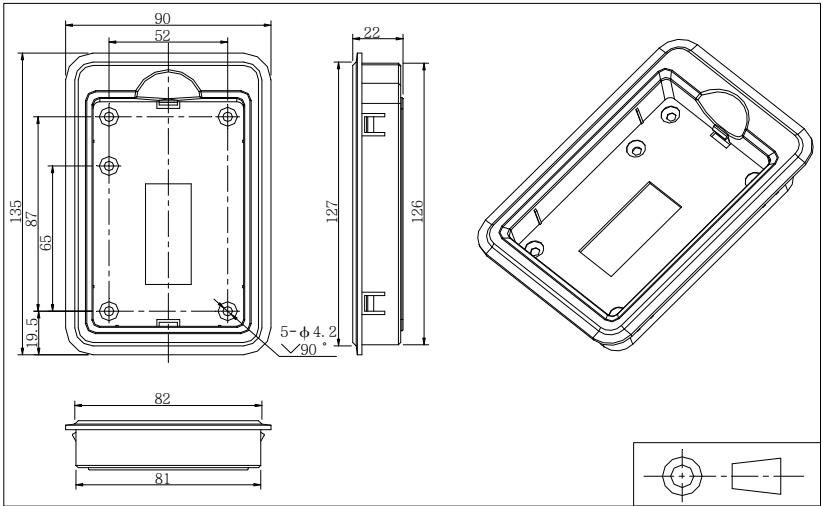

Figure 7-10: Keyboard warehouse dimension diagram (dimension unit: mm)

PI500-W Keyboard installation open size diagram:

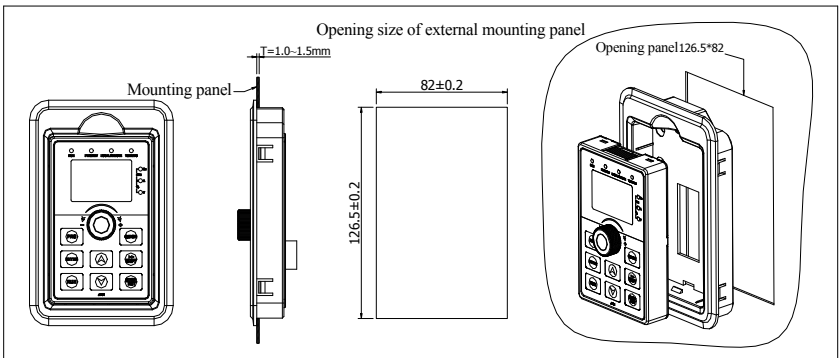

Figure 7-11: Keyboard installation opening dimension diagram (dimension unit: mm)

Notes:

1. The keyboard compartment is installed on the panel of the inverter with square hole required.
2. The overall dimension of LED keyboard is fully compatible with that of LCD keyboard.

Chapter 8 Maintenance and repair

8-1.Maintenance and repair

During normal use of the inverter, in addition to routine inspections, the regular inspections are required (e.g. the overhaul or the specified interval, and the interval shall not exceed 6 months), please refer to the following table to implement the preventive measures.

Check Date		Check Points	Check Items	Check to be done	Method	Criterion
Routine	Regular					
√		Display	LED display	Whether display is abnormal or not	Visually check	As per use status
√	√	Cooling system	Fan	Whether abnormal noise or vibration exists or not	Visually and audibly check	No abnormal
√		Body	Surrounding conditions	Temperature, humidity, dust, harmful gas.	Visually check with smelling and feeling	As per Section 2-1
√		Input/output terminals	Voltage	Whether input/output voltage is abnormal or not	Test R, S, T and U, V, W terminals	As per standard specifications
	√	Main circuit	Overall	Whether these phenomenon of loose fastenings, overheat, discharging, much dust, or blocked air duct exist or not	Visually check, tighten and clean	No abnormal
			Electrolytic capacitance	Whether appearance is abnormal or not	Visually check	No abnormal
			Wires and conducting bar	Whether they are loose or not	Visually check	No abnormal
			Terminals	If screws or bolts are loose or not	Tighten	No abnormal

"√" means routine or regular check to be needed

Do not disassemble or shake the device gratuitously during check, and never unplug the connectors, otherwise the system will not run or will enter into fault state and lead to component failure or even damage to the main switching device such as IGBT module.

The different instruments may come to different measurement results when measuring. It is recommended that the pointer voltmeter shall be used for measuring input voltage, the rectifier voltmeter for output voltage, the clamp-on ammeter for input current and output current, and the electric wattmeter for power.

8-2.Parts for regular replacement

To ensure the reliable operation of inverter, in addition to regular care and maintenance, some internal mechanical wear parts (including cooling fan, filtering capacitor of main circuit for energy storage and exchange, and printed circuit board) shall be regularly replaced. Use and replacement

for such parts shall follow the provisions of below table, also depend on the specific application environment, load and current status of inverter.

Name of Parts	Standard life time
Cooling fan	1 to 3 years
Filter capacitor	4 to 5 years
Printed circuit board(PCB)	5 to 8 years

8-3.Storage

The following actions must be taken if the inverter is not put into use immediately(temporary or long-term storage) after purchasing:

※It should be store at a well-ventilated site without damp, dust or metal dust, and the ambient temperature complies with the range stipulated by standard specification

※Voltage withstand test can not be arbitrarily implemented, it will reduce the life of inverter. Insulation test can be made with the 500-volt megger before using, the insulation resistance shall not be less than 4MΩ.

8-4.Capacitor

8-4-1.Capacitor rebuilt

If the frequency inverter hasn't been used for a long time, before using it please rebuilt the DC bus capacitor according the instruction. The storage time is counted from delivery.

Time	Operation instruction
Less than 1 year	No need to recharge
Between 1~2 years	Before the first time to use, the frequency inverter must be recharged for one hour
Between 2~3years	Use adjustable power to charge the frequency inverter: --25% rated power 30 minutes, -- 50% rated power 30minutes, -- 75% rated power 30minutes, --Last 100% rated power 30minutes
More than 3 years	Use adjustable power to charge the frequency inverter: --25% rated power 2hours, --50% rated power 2 hours, -- 75% rated power 2hours, -- Last 100% rated power 2hours

Instruction of using adjustable power to charge the frequency inverter:

The adjustable power is decided by the frequency inverter input power, for the single phase/3 phase 220v frequency inverter, we use 220v AC/2A Regulator. Both single phase and three phase frequency inverter can be charged by single phase Power Surge(L+ connect R,N connects T) Because it is the same rectifier,so all the DC bus capacitor will be charged at the same time.

You should make sure the voltage(380v) of high voltage frequency inverter, because when the capacitor being charged it almost doesn't need any current, so small capacitor is enough(2A)

The instruction of using resistor(incandescent lights) to charge frequency inverters:

When charge the DC bus capacitor of drive system by connecting power directly, then the time should not be less than 60 minutes. The operation should be carried on under the condition of normal temperature and without load, and moreover ,should be added resistor in the power supply cycle.

380V drive system: use 1K/100W resistor. When the power is less than 380v, 100w incandescent lights is also suitable. When using incandescent lights, the lights will extinct or become very weak.

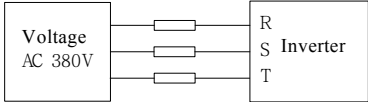

Figure 8-1:380V Drive equipment charging circuit example

8-5.Measuring and readings

- ※ If a general instrument is used to measure current, imbalance will exist for the current at the input terminal. generally, the deviation is not more than 10%, that is normal. If the deviation exceeds 30%, please inform the original manufacturer to replace rectifier bridge, or check if the deviation of three-phase input voltage is above 5V or not.
- ※ If a general multi-meter is used to measure three-phase output voltage, the reading is not accurate due to the interference of carrier frequency and it is only for reference.

Chapter 9 Optional part

9-1. Power cables

The dimension of input power cable and motor cable should meet the local provision:

Input power cable and motor cable should bear the related load current

The maximum rated temperature margin conditions of the motor cable should not be sustained below 70 degrees .

Conductivity of the PE conductor and phase conductor capacity are the same(same cross-sectional area)

About EMC requirements, see "EMC Guidance Content"

To meet the CE EMC requirements, a symmetrical shielded motor cable must be used (see figure below).

For input cables can use four-core cable, but still recommended to use shielded symmetrical cable. Compared to a four-core cable, shielded symmetrical cables can not only reduce the loss and cost of the current flowing through the motor cable, but also can reduce the electromagnetic radiation.

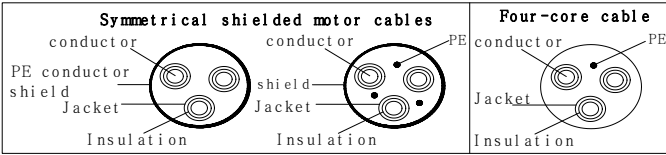

Note: If conductivity of the cable shield can not meet the requirements, you must use a separate PE conductor.

To play a protective role of conductor, when the shield wire and phase conductors using the same material, the cross-sectional area of the shield wire and phase conductors cross-sectional area must be the same, aims to reduce grounding resistance, impedance continuity better

To effectively suppress RFI transmission and conduction, the shield conductivity must be at least 1/10 of the phase conductor conductivity. For copper or aluminum shield, this requirement is very easy to meet. Minimum requirements for the drive motor cable as shown below. Cable comprising a layer of copper spiral. Shield tight as possible, that the more tightly the more we can effectively suppress radiated electromagnetic interference.

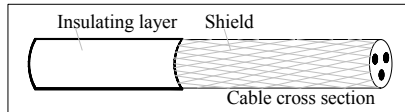

9-2. Control cable

All analog control cables and cables for the frequency input must be shielded. Analog signal cable double-shielded twisted pair cable as shown in Figure 1. Each signal uses one pair individually shielded twisted pair cable pair. Do not use the different analog signal with a ground wire.

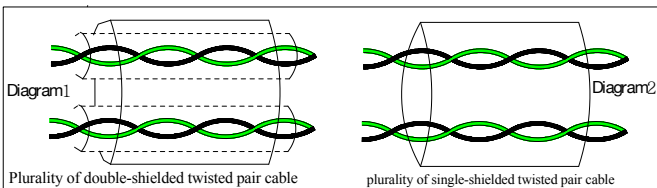

For low-voltage digital signals, double-shielded cable is the best choice, but can also be asingle-shielded or unshielded twisted pair, as shown in Figure 2, however, the frequency of the signal, it can only use a shielded cable.

Relay cable need to use cables with metal braid shield.

Need to use a network cable to connect the keyboard, for electromagnetic environment is more complex place, it is recommended to use shielded cable.

Note: analog and digital signals using different cables routed separately.

9-3. Interference counte

Connect noise filter on the output side of inverter can reduce inductive interference and radio interference .

→Inductive interference :The electromagnetic induction makes the signal line noise when upload signal ,and then cause the control equipment malfunction.

→ Wireless interference :The high-frequency electromagnet wave emitted by the inverter and cables will interfere with the nearby wireless device and make it noise when receiving signal.

→ Installation of noise filter as below :

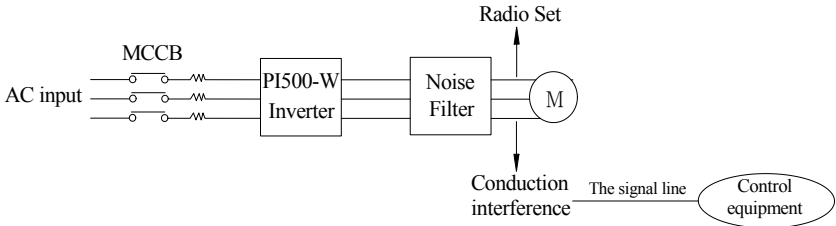

(1)Inductive interference countermeasure : in addition to the installation of noise filter , it can also import the output cables to grounded metal tube. The distance between the output cable and signal line is greater than 30 cm , the influence of inductive interference is also significantly reduced . As shown below :

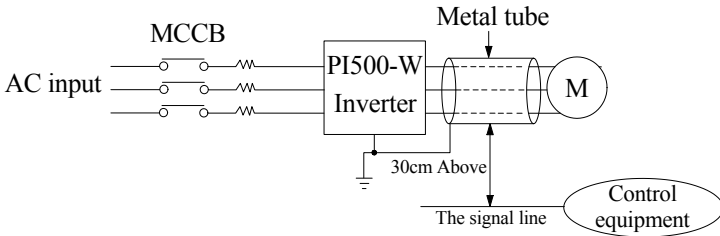

(2)Radio frequency (RF) interference countermeasure : the input cables, output cables and inverter itself can produce interference , to install noise filter on both sides of input and output and shield the inverter with metal box can reduce the radio frequency interference . As shown below :

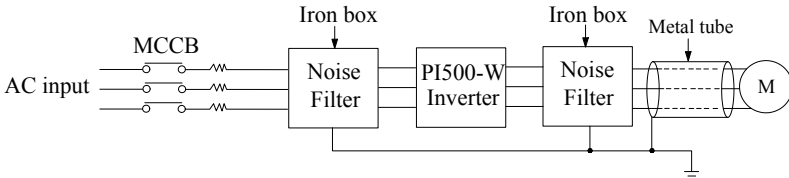

Chapter 10 Warranty

The product quality shall comply with the following provisions (overseas market):

1. Warranty terms

1-1. The product from the ex-factory date, the warranty period of 18 months(except non-standard products), It is based on factory records.

1-2. The product from the ex-factory date. if the product appear quality problem within the normal operating range. we provide free warranty under 18 months.

1-3. The product from the ex-factory date, enjoy lifelong compensable service.

If there is a contract, we will according to the priority principle of the contract.

2. Exceptions clause

If belongs to the quality problems caused by following reasons products, we provide compensable service even though under the warranty. we will charge a maintenance fee.

2-1. The user is not in accordance with the "products manual" is used method of operation

caused the failure.

2-2. Users without permission to alteration or repair caused by product failure.

2-3. Users beyond the standard specifications require the use of the inverter caused by product failure.

2-4. Users to buy and then fell loss or damage caused by improper handling.

2-5. Because the user use adverse environment (such as: Humid environment, Acid and alkaline corrosion gas and so on) lead to product failure.

2-6. Due to the fault cause of earthquake, fire, lightning, wind or water disaster, abnormal

voltage irresistible natural disasters.

2-7. Damaged during shipping ,but users are not rejected goods.

3. The following conditions, manufacturers have the right not to be warranty.

3-1. No product nameplate or product nameplate blurred beyond recognition.

3-2. Not according to the purchase contract agreement to pay the money.

3-3. For installation, wiring, operation, maintenance and other users can not describe the objective reality to the company's technical service center.

4. About the repair fee, according to our company latest price list as a standard.

5. When the products is broken, please complete the form and warranty card, shipping with the failure machine to our company.

6. Dalian Powtran Technology Co.,Ltd reserve the right to explain the terms of the event.

Appendix I RS485 Communication protocol

I-1 Communication protocol

I-1-1 Communication content

This serial communication protocol defines the transmission information and use format in the series communication including: master polling(or broadcast) format; master encoding method, and contents including: function code of action, transferring data and error checking. The response of slave also adopts the same structure, and contents including: action confirmation, returning the data and error checking etc. If slave takes place the error while it is receiving information or cannot finish the action demanded by master, it will send one fault signal to master as a response.

Application Method

The inverter will be connected into a “Single-master Multi-slave” PC/PLC control network with RS485 bus.

Bus structure

(1)Transmission mode

Asynchronous series and half-duplex transmission mode. For master and slave, only one of them can send the data and the other only receives the data at the same time. In the series asynchronous communication, the data is sent out frame by frame in the form of message

Topological structure

Single-master and multi-slave system. The setting range of slave address is 0 to 247, and 0 refers to broadcast communication address. The address of slave for network must be exclusive

Diagram I-3 is the single inverter and PC set up MODBUS field wiring diagram. Because computers are generally not with RS485 interface, the computer must be built-in RS232 interface or USB interface through the converter to convert to RS485. Connect the T + of converter with 485 + terminal of the inverter, Connect the T - of converter with 485 - terminal of inverter. We recommended to use a shielded twisted pair. When adopting the RS232-485 converter, RS232 interface connected with RS232-RS485 RS232 interface, the cable should be as short as possible, 15meters at the longest, we recommend to plug the RS232-RS485 with computer in pair directly. Similarly, when using the USB-RS485 converter, cable should be as short as possible.

When the line is connected, connect the right port of the host computer on the computer to (RS232-RS485 converter port, such as COM1), and set the basic parameters and the baud rate and data bit parity and so on consistent with the inverter.

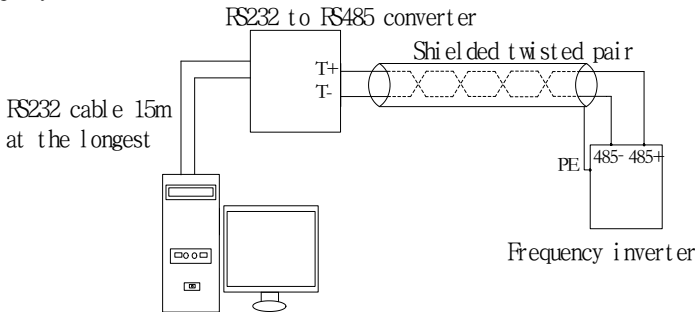

Figure I-3

Multiple Applications

In reality, multi-machine applications, there are two connections

The first inverter and the last inverter short the terminal resistor on the control board to be active. As shown in Figure I-4

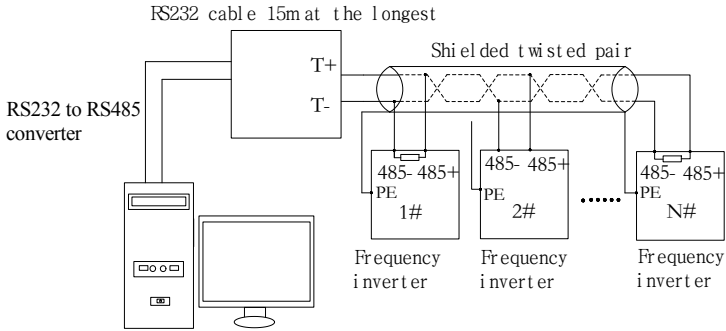

Figure I-4

The two longest distance inverter from the device shall short the terminal resistor on the control board to be active. As shown in Figure I-5:

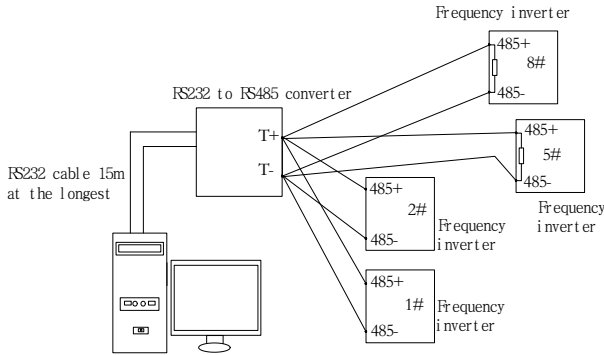

Figure I-5

Multi-machine connection should try to use a shielded cable. The basic parameters such as baud rate and data bit of all of the devices on RS485 line must be the same, address must be different.

NOTE: The terminal resistor of 485 decides valid or invalid through the control board(No. 485) jumper

I-1-2 Protocol description

PI500 series inverter communication protocol is a asynchronous serial master-slave communication protocol, in the network, only one equipment(master) can build a protocol (known as "Inquiry/Command"). Other equipment(slave) only can response the "Inquiry/Command"of master by providing data or perform the corresponding action according to the "Inquiry/Command"of master. Here, the master refers to a Personnel Computer(PC), an industrial control device or a programmable logic controller (PLC), etc. and the slave refers to PI500 inverter. Master can communicate with individual slave, also send broadcasting information to all the lower slaves. For the single "Inquiry/Command"of master, slave will return a signal(that is a response) to master; for the broadcasting information sent by master, slave does not need to feedback a response to master.

Communication data structure PI500 series inverter's Modbus protocol communication data format is as follows: in RTU mode, messages are sent at a silent interval of at least 3.5 characters. There are diverse character intervals under network baud rate,

which is easiest implemented. The first field transmitted is the device address.

The allowable characters for transmitting are hexadecimal 0 ... 9, A ... F. The networked

Appendix I

devices continuously monitor network bus, including during the silent intervals. When the first field (the address field) is received, each device decodes it to find out if it is sent to their own. Following the last transmitted character, a silent interval of at least 3.5 characters marks the end of the message. A new message can begin after this silent interval.

The entire message frame must be transmitted as a continuous stream. If a silent interval of more than 1.5 characters occurs before completion of the frame, the receiving device will flushes the incomplete message and assumes that the next byte will be the address field of a new message. Similarly, if a new message begins earlier than the interval of 3.5 characters following a previous message, the receiving device will consider it as a continuation of the previous message. This will result in an error, because the value in the final CRC field is not right.

RTU frame format :

Frame header START	Time interval of 3.5characters
Slave address ADR	Communication address: 1 to 247
Command code CMD	03: read slave parameters;06: write slave parameters
Data content DATA(N-1)	Data content: address of function code parameter, numbers of function code parameter, value of function code parameter, etc.
Data content DATA(N-2)	
.....	
Data content DATA0	Detection Value: CRC value.
CRC CHK high-order	
CRC CHK low-order	
END	Time interval of 3.5characters

CMD (Command) and DATA (data word description)

Command code: 03H, reads N words (Max.12 words), for example: for the inverter with slave address 01, its start address F0.02 continuously reads two values.

Master command information

ADR	01H
CMD	03H
Start address high-order	F0H
Start address low-order	02H
Number of registers high-order	00H
Number of registers low-order	02H
CRC CHK low-order	CRC CHK values are to be calculated
CRC CHK high-order	

Slave responding information

When F9.05 is set to 0:

ADR	01H
CMD	03H
Byte number high-order	00H
Byte number low-order	04H
Data F002H high-order	00H
Data F002H low-order	01H
Data F003H high-order	00H
Data F003H low-order	01H
CRC CHK low-order	CRC CHK values are to be calculated
CRC CHK high-order	

When F9.05is set to 1:

ADR	01H
CMD	03H
Byte number	04H
Data F002H high-order	00H
Data F002H low-order	01H
Data F003H high-order	00H
Data F003H low-order	01H

CRC CHK low-order	CRC CHK values are to be calculated
CRC CHK high-order	

Command Code: 06H, write a word. For example: Write 5000(1388H)into the address F013H of the inverter with slave address 02H.

Master command information

ADR	02H
CMD	06H
Data address high-order	F0H
Data address low-order	13H
Data content high-order	13H
Data content low-order	88H
CRC CHK low-order	CRC CHK values are to be calculated
CRC CHK high-order	

Slave responding information

ADR	02H
CMD	06H
Data address high-order	F0H
Data address low-order	13H
Data content high-order	13H
Data content low-order	88H
CRC CHK low-order	CRC CHK values are to be calculated
CRC CHK high-order	

I-2 Check mode:

Check mode - CRC mode: CRC (Cyclical Redundancy Check) adopts RTU frame format, the Message includes an error-checking field that is based on CRC method. The CRC field checks the whole content of message. The CRC field has two bytes containing a 16-bit binary value. The CRC value calculated by the transmitting device will be added into to the message. The receiving device recalculates the value of the received CRC, and compares the calculated value to the Actual value of the received CRC field, if the two values are not equal, then there is an error in the transmission.

The CRC firstly stores 0xffff and then calls for a process to deal with the successive eight-bit Bytes in message and the value of the current register. Only the 8-bit data in each character is valid to the CRC, the start bit and stop bit, and parity bit are invalid.

During generation of the CRC, each eight-bit character is exclusive OR(XOR) with the register

Contents separately, the result moves to the direction of least significant bit(LSB), and the most significant bit(MSB) is filled with 0. LSB will be picked up for detection, if LSB is 1, the register will be XOR with the preset value separately, if LSB is 0, then no XOR takes place. The whole process is repeated eight times. After the last bit (eighth) is completed, the next eight-bit byte will be XOR with the register's current value separately again. The final value of the register is the CRC value that all

The bytes of the message have been applied.

When the CRC is appended to the message, the low byte is appended firstly, followed by the high byte. CRC simple functions is as follows:

```
Unsigned int crc_chk_value(unsigned char *data_value,unsigned char length)
```

```
{
    unsigned int crc_value=0xFFFF;

    int i;
    while(length--)
    {
        crc_value^=*data_value++;
    }
}
```

```

for(i=0;i<8;i++)
{
    if(crc_value&0x0001)
    {
        crc_value=(crc_value>>1)^0xa001;
    }
    else
    {
        crc_value=crc_value>>1;
    }
}
return(crc_value);
}
}

```

I-3 Definition of communication parameter address

The section is about communication contents, it’s used to control the operation, status and related parameter settings of the inverter. Read and write function-code parameters (Some functional code is not changed, only for the manufacturer use or monitoring): the rules of labeling function code parameters address:

The group number and label number of function code is used to indicate the parameter address:

High byte: F0 to FB (F group), A0 to AF (E group), B0 to BF(B group),C0 to C7(Y group),70 to 7F (d group) low byte: 00 to FF, This address is written to EEPROM

For example: address F3.12 indicates F30C; Note: L0 group parameters: neither read nor change;d_group parameters: only read, not change.

Parameter address	EEPROM Address	Parameter	EEPROM Address
d0.00 to d0.41	7000 to 7029	FA.00 to FA.07	FA00 to FA07
F0.00 to F0.27	F000 to F029	Fb.00 to Fb.09	Fb00 to Fb09
F1.00 to F1.46	F100 to F12E	FC.00 to FC.02	FC00 to FC02
F2.00 to F2.19	F200 to F213	E0.00 to E0.11	A000 to A00b
F3.00 to F3.15	F300 to F30F	E1.00 to E1.51	A100 to A133
F4.00 to F4.14	F400 to F40E	E2.00 to E2.32	A200 to A220
F5.00 to F5.15	F500 to F50F	E3.00 to E3.21	A300 to A315
F6.00 to F6.21	F600 to F615	b0.00 to b0.35	B000 to B023
F7.00 to F7.54	F700 to F736	y0.00 to y0.04	C000 to C004
F8.00 to F8.35	F800 to F823	y1.00 to y1.30	C100 to C11e
F9.00 to F9.07	F900 to F907		

Some parameters can not be changed during operation, but some parameters can not be changed regardless of the inverter is in what state. When changing the function code parameters, please pay attention to the scope, units, and relative instructions on the parameter.

Besides, due to EEPROM is frequently stored, it will redUce the life of EEPROM, therefore under the communication mode some function code do not need to be stored and you just change the RAM value.

If F group parameters need to achieve the function, as long as change high order F of the function code address to 0. If E group parameters need to achieve the function, as long as change high order A of the function code address to 4. The corresponding function code addresses

are indicated below: high byte: 00 to 0F(F group), 40 to 4F (E group), 50 to 5F(B group),60 to 67(Y group)low byte:00 to FF,this address is written RAM

For example:

Function code F3.12 can not be stored into EEPROM, address indicates as 030C; function code E3.05 can not be stored into EEPROM, address indicates as 4305; the address indicates that only writing RAM can be done and reading can not be done, when reading, it is invalid address. For all parameters, you can also use the command code 07H to achieve the function.

Stop/Run parameters section:

Parameter address	Parameter description	Parameter address	Parameter description
1000	*Communication set value (-10000 to 10000)(Decimal)	1011	PID feedback
1001	Running frequency	1012	PLC step
1002	Bus voltage	1013	High-speed pulse input frequency, unit:0.01kHz
1003	Output voltage	1014	Feedback speed, unit:0.1Hz
1004	Output current	1015	Remaining run time
1005	Output power	1016	AI1 voltage before correction
1006	Output torque	1017	AI2 voltage before correction
1007	Operating speed	1018	AI3 voltage before correction
1008	DI input flag	1019	Linear speed
1009	DO output flag	101A	Current power-on time
100A	AI1 voltage	101B	Current run time
100B	AI2 voltage	101C	High-speed pulse input frequency, unit: 1Hz
100C	AI3 voltage	101D	Communication set value
100D	Count value input	101E	Actual feedback speed
100E	Length value input	101F	Master frequency display
100F	Load speed	1020	Auxiliary frequency display
1010	PID setting		

Note:

There is two ways to modify the settings frequencies through communication mode:

The first: Set F0.03 (main frequency source setting) as 0/1 (keyboard set frequency), and then modify the settings frequency by modifying F0.01 (keyboard set frequency). Communication mapping address of F0.01 is 0xF001 (Only need to change the RAM communication mapping address to 0x0001).

The second :Set F0.03 (main frequency source setting) as 9 (Remote communication set), and then modify the settings frequency by modifying (Communication settings). , mailing address of this parameter is 0x1000.the communication set value is the percentage of the relative value, 10000 corresponds to 100.00%, -10000 corresponds to -100.00%. For frequency dimension data, it is the percentage of the maximum frequency (F0.19); for torque dimension data, the percentage is F5.08(torque upper limit digital setting).

Control command is input to the inverter: (write only)

Command word address	Command function	
2000	0001:Forward run	0005:Free stop
	0002:Reverse run	0006: Deceleration and stop
	0003:Forward Jog	0007:Fault reset
	0004:Reverse Jog	

Inverter read status: (read-only)

Status word address	Status word function
3000	0001:Forward run
	0002:Reverse run
	0003:Stop

Appendix I

Parameter lock password verification: (If the return code is 8888H, it indicates that password verification is passed)

Password address	Enter password
C000	*****

Digital output terminal control: (write only)

Command address	Command content
2001	BIT0: SPA output control BIT1: RELAY2 output control BIT2 RELAY1 output control BIT3: Manufacturer reserves the undefined BIT4: SPB switching quantity output control

Analog output DA1 control: (write only)

Command address	Command content
2002	0to7FFFindicates 0% to 100%

Analog output DA2 control: (write only)

Command address	Command content
2003	0 to 7FFF indicates 0% to 100%

SPB high-speed pulse output control: (write only)

Command address	Command content
2004	0 to 7FFF indicates 0% to 100%

Inverter fault description:

Inverter fault address:	Inverter fault information:	
8000	0000:No fault	0014:Encoder/PG card abnormal
	0001:Inverter unit protection	0015:Parameter read and write abnormal
	0002:Acceleration overcurrent	0016:Inverter hardware fault
	0003:Deceleration overcurrent	0017:Motor short to ground fault
	0004:Constant speed overcurrent	0018:Reserved
	0005:Acceleration overvoltage	0019:Reserved
	0006:Deceleration overvoltage	001A:Running time arrival
	0007:Constant speed overvoltage	001B: Customer self-defined fault 1
	0008:Control power failure	001C: Customer self-defined fault 2
	0009:Undervoltage fault	001D: Power-on time arrival
	000A:Inverter overload	001E:Load drop
	000A:Inverter overload	001F:PID feedback loss when running
	000A:Inverter overload	0028:Fast current limiting timeout
	000B:Motor Overload	0029:Switch motor when running fault
	000C:Input phase loss	002A: Too large speed deviation
	000D:Output phase loss	002B:Motor overspeed
	000E:Module overheating	002D:Motor overtemperature
	000F:External fault	005A:Encoder lines setting error
	0010:Communication abnormal	005B: Missed encoder
	0011:Contactor abnormal	005C:Initial position error
0012:Current detection fault	005E:Speed feedback error	
0013:Motor parameter auto tuning fault		

Data on communication failure information description (fault code):

Communication fault address	Fault function description	
8001	0000:No fault	0005:Invalid parameters
	0001:Password error	0006:Invalid parameter changes
	0002:Command code error	0007:System locked

	0003:CRC check error	0008:EEPROM in operation
	0004:Invalid address	

F9Group - Communication parameter description

F9.00	Baud rate	Default	6005
	Setting range	Units digit : MODUBUS baud rate	
		0:300BPS	5:9600BPS
		1:600BPS	6:19200BPS
		2:1200BPS	7:38400BPS
		3:2400BPS	8:57600BPS
		4:4800BPS	9:115200BPS
	Tens digit:Profibus-DP0:115200BPS		
	Hundreds digits:reserved 0: reserved		
Thousands digits:CAN baud rate 6:1M			

This parameter is used to set the data transfer rate between the host computer and the inverter.
Note: the baud rate must be set to the same for the host computer and the inverter, otherwise communication can not be achieved. The larger baud rate, the faster communication speed.

F9.01	Data format	Default	0
	Setting range	0: No parity: data format <8, N, 2> 1: Even parity: data format <8, E, 1> 2: Odd parity: data format <8, O, 1> 3: No parity: data format <8-N-1>	

Note: the set data for the host computer and the inverter must be the same.

F9.02	This unit address	Default	1
	Setting range	1 to 247, 0for broadcast address	

When the address of this unit is set 0, that is broadcast address, the broadcasting function for the host computer can be achieved.

The address of this unit has uniqueness (in addition to the broadcast address), which is the basis of peer-to-peer communication for the host computer and the inverter.

F9.03	Response delay	Default	2ms
	Setting range	0 to 20ms	

Response delay: it refers to the interval time from the end of the inverter receiving data to the start of it sending data to the host machine. If the response delay is less than the system processing time, then the response delay time is subject to the system processing time; If the response delay is longer than the system processing time, after the system finishes the data processing, and continues to wait until the response delay time, and then sends data to the host computer.

F9.04	Reserved	Factory value	
-------	----------	---------------	--

Communication time-out parameter is not valid when the function code is set to 0.0s.

When the function code is set to valid, if the interval time between one communication and the next communication exceeds the communication time-out time, the system will report communication failure error (Fault ID Err.16). Generally, it is set to invalid. If the parameter can be set to monitor the communication status in continuous communication system.

F9.05	Communication protocol selection	Factory value	0
	Setting range	0: Non-standard Modbus protocol 1:Standard Modbus protocol	

F9.05=1: select standard Modbus protocol.

F9.05=0: when reading command, the number of bytes returned by slave is more 1 byte than standard Modbus protocol.

F9.06	Communication read current resolution	Factory value	0
	Setting range	0: 0.01A 1: 0.1A	

Used to determine the current output units when communication reads output current.

Appendix II Application cases of constant pressure water supply

II -1 Wiring and installation instructions

PI500-W Case Study of Constant Pressure Water Supply by Driving Multiple Pumps

II -1-1 Diagram

Diagram of Connecting a Frequency Inverter to Drive Four Pumps t

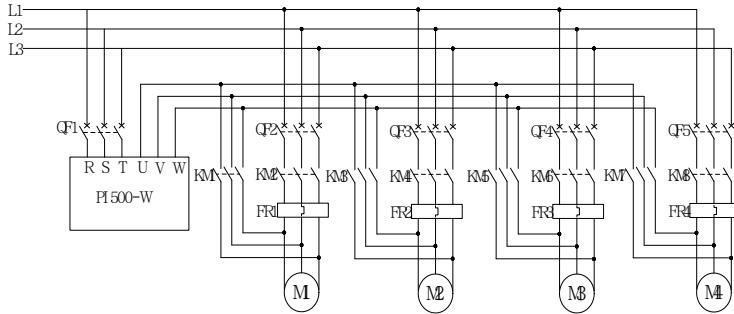

Main Circuit Control diagram

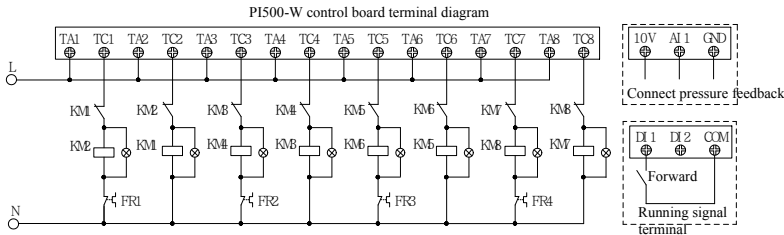

Connect the circuit according to the main circuit and control.

II -1-2 Parameter setting

- (1) Check the wiring to ensure the accuracy of wiring;
- (2) Set the starting pump number E8.15 (according to the connection M1 named A motor, M2 named B motor, M3 named C motor, M4 named D motor), according to the field requirement to start the motor needed first. If M2 motor starts first, set E8.15=2.
- (3) Set up according to the actual situation E8.24 to E8.27;
- (4) Single motor confirms that the direction of motor steering is the same, and the direction of frequency inverter control rotation is the same as power frequency rotation. For example, starting the inverter to observe the direction of rotation is the direction of pumping, and then starting the power frequency to observe the direction of rotation is the direction of pumping. If the direction of rotation of the frequency inverter mode is incorrect, arbitrarily switch two phases of KM1; if the direction of rotation of the power frequency mode is incorrect, arbitrarily switch two phases of KM2.
- (5) Pressure gauge range (E8.04), dormancy and wake-up frequency, increase pump pressure, decrease pump pressure, low-pressure and high-pressure alarm, time and pressure setting of multi-stage pressure water supply, selection of motor rotation according to the actual situation. Please see E8 functional parameters for details.
- (6) About PID control adjustment, proportional gain E2.13, integral time E2.14, can be

adjusted on the basis of factory value, please adjust according to the time situation.

(7)Parameters

Parameter code	Description
d0.40	Feedback pressure detection value
F0.11	Command Source Selection
F2.01~F2.08	Selection of Output Function of Control Board Terminal Relay
F7.46~F7.49	Wake-up and sleep Frequency Settings. Use it together with E8.19~E8.23
E8 group	Constant Pressure Water Supply parameters
E2.02	Water pressure feedback channel,0:A11 feedback 1:A12 feedback
E2.06	PID deviation limit
E2.13	PID proportional gain
E2.14	PID itegration

(8) Explanation of one inverter drives 4 pumps

Pump instructions:

Inverter A pump begins running, the frequency is bigger than F0.21; and feedback pressure is less than the set pressure (E8.07), and lasts until the delay time set by E8.08, when the pump condition is satisfied, the pump is added. The system is switched according to the sequence principle of frequency conversion A pump and frequency conversion pump plus one:

A Pump running normally→add pump when pressure is insufficient→Frequency conversion shutdown operation of pump A→Delay time after frequency inverter frequency switch to power frequency(E8.09)→A pump running at power frequency→frequency inverter frequency(E8.10)→B pump frequency inverter running→add pump when pressure is insufficient→Frequency conversion shutdown operation of pump B→Delay time after frequency inverter frequency switch to power frequency(E8.09)→B pump running at power frequency→frequency inverter frequency(E8.10)→C pump running at power frequency→add pump when pressure is insufficient→Frequency conversion shutdown operation of pump C→Delay time after frequency inverter frequency switch to power frequency(E8.09)→C pump rning at power frequency→frequency inverter frequency(E8.10)→D pump frequency inverter running.

Pump reduction instructions:

If the A, B and C pumps are power frequency, the D pump is frequency inverter.

When the frequency inverter pump runs to E8.13 pump reduction frequency and the feedback pressure E8.12, after continuing the delay time of E8.14 pump reduction, the pump reduction is started. The system starts in sequence, starts first according to the normal principle, stops first, stops the power frequency A pump ,power frequency B ,pump power frequency C pump.

II - 2 Wiring and commissioning instructions

PI500-w constant pressure water supply inverter drives several pumps to realize constant pressure water supply;

II - 2-1 Wiring diagram

- (1) Main circuit diagram of constant pressure water supply realized by one inverter driving two water pumps with variable frequency switch (factory default is this mode)

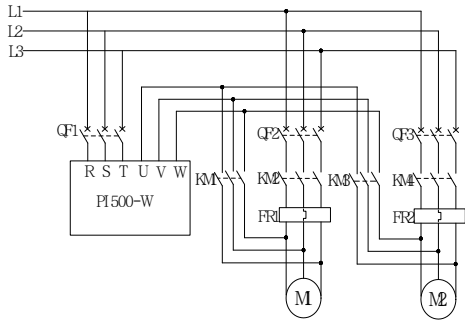

Wiring diagram of two water pumps driven by one inverter

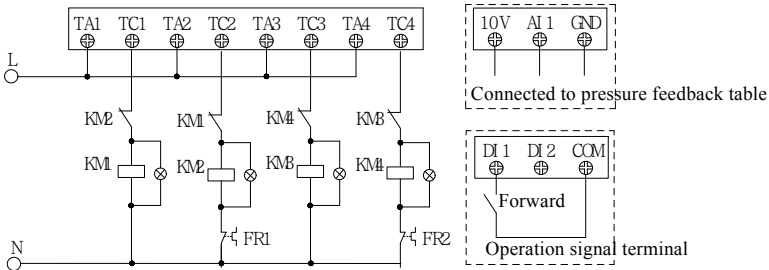

PI500-W Terminal wiring diagram of control board

(2) The main circuit diagram of constant pressure water supply is realized by driving four pumps with one frequency converter (e8.33 and e8.34 must be set as 1)

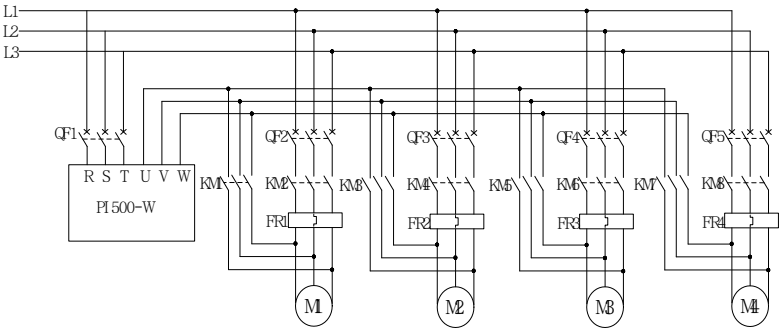

One inverter drives four water pumps, and the connection diagram of frequency conversion switching control circuit is as follows:

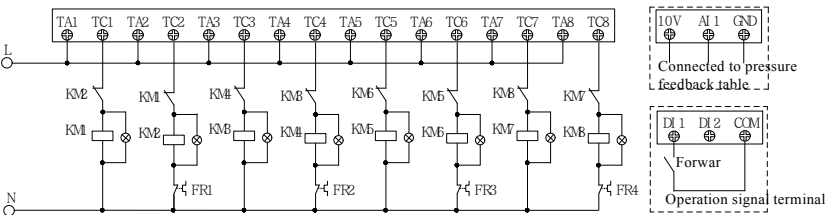

PI500-W Terminal wiring diagram of control board

(2) One fixed frequency conversion motor + 3 power frequency water supply main circuit wiring diagram (e8.32, e8.33, e8.34 must be set as 2)

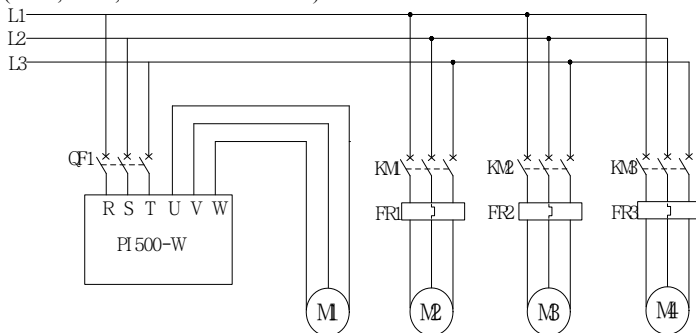

One fixed frequency conversion motor + 3 power frequency water supply control circuit wiring diagram:

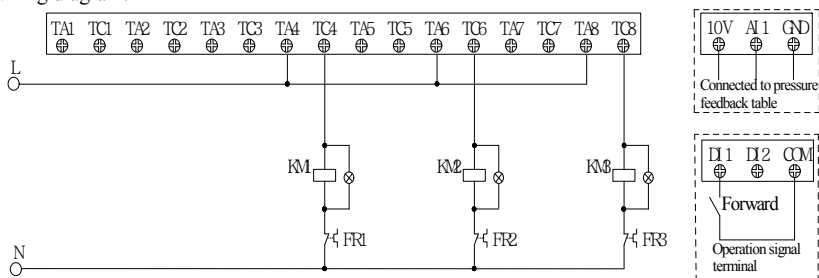

PI500-W Terminal wiring diagram of control board

Connect the circuit according to the main circuit and control circuit.

II - 2-2 Parameter setting and debugging

- (1) Check the circuit to ensure the accuracy of wiring;
- (2) The special function group of constant pressure water supply is group E8. Please check the instructions of group E8 for details. You can directly enter group E8 with quick key for keyboard operation.
- (3) Input the motor name plate parameters to group B0;
- (4) According to the actual situation, set e8.31-e8.38. If the above function code is selected as 1, the frequency conversion motor is selected; if the above function code is selected as 2, the power frequency motor is selected, and the factory default is "one drives two" (select two variable frequency motors);
- (5) Confirm that the rotation direction of single motor is consistent, and the rotation direction of frequency conversion control is consistent with that of power frequency. Taking M1 motor as an example, start the frequency converter to observe that the rotation direction is the pumping direction, and then observe the rotation direction is the pumping direction when starting at power frequency. If the rotation direction of frequency conversion mode is not correct, replace two phases of KM1 at will; if the rotation direction of power frequency mode is not correct, arbitrarily switch two of km2.
- (6) According to the actual situation, set the range of pressure meter (e8.05), sleep and wake-up frequency, increase pump pressure, reduce pump pressure, low-pressure and high-pressure alarm, time period and pressure setting of multi-stage pressure water supply, and motor frequency

conversion attribute selection. For the special group of constant pressure water supply, see E8 group function parameters for details.

(7) About PID control adjustment, proportional gain e8.65, integral time e8.66, can be fine tuned on the basis of factory value, please adjust according to the time.

(8) Description of addition and subtraction motor

When the condition of adding motor is satisfied, the frequency conversion motor is preferred, and the power frequency motor is added if there is no frequency conversion motor. For the system with multiple motors running at the same time, only one motor is under the control of frequency converter, and the others are under power frequency control. When the motor reduction conditions are met, the power frequency motor will be reduced until the power frequency motor is left. For specific functions, please refer to E8 group special function code.

(9) For the constant pressure water supply system with one driving multiple units, only when the system has and only one variable frequency motor is in operation, it can support the sleep and wake-up function. For the sleep wake-up function, please refer to e8-22 ~ e8-30.

(10) Set pressure: see e8.39 ~ e8.54 for details. If there is no need to set the pressure time period, only set e8.40 pressure value;

(11) Pressure linkage: increase pump pressure, reduce pump pressure and explosion-proof pressure are associated with set pressure;

Upper offset: the pressure value that is more than the set pressure (pump pressure = set pressure + pump pressure up offset);

Lower offset: the pressure value less than the set pressure (increase pump pressure = set pressure - increase pump pressure lower offset);

Note: if the set pressure is changed, the increase and decrease of pump pressure will follow the set pressure, and the change is the set offset. When the set pressure needs to be changed, the change of other parameters should be reduced.

Product information feedback

Dear user:

Thank you for your interest in and purchasing Powtran products! In order to better serve you, we want to be able to timely get your personal information and the related information of the purchased Powtran products so as to understand your further demands for our Powtran products, we would appreciate your valuable feedback. For your convenience, please visit our website <http://www.powtran.com> and then click "Technologies and Services" and "Download" columns to submit your feedback information.

- 1) Download the update product manuals you need
- 2) View the technical information on products, such as operation instructions, specifications and features, FAQ, etc.
- 3) Share application cases.
- 4) Technical advisory and online feedback
- 5) Feedback the product and demand information via e-mail
- 6) Inquire the latest products and access to various types of warranty and extend additional services

По вопросам продаж и поддержки обращайтесь:

Алматы (7273)495-231
Ангарск (3955)60-70-56
Архангельск (8182)63-90-72
Астрахань (8512)99-46-04
Барнаул (3852)73-04-60
Белгород (4722)40-23-64
Благовещенск (4162)22-76-07
Брянск (4832)59-03-52
Владивосток (423)249-28-31
Владикавказ (8672)28-90-48
Владимир (4922)49-43-18
Волгоград (844)278-03-48
Вологда (8172)26-41-59
Воронеж (473)204-51-73
Екатеринбург (343)384-55-89
Иваново (4932)77-34-06
Ижевск (3412)26-03-58
Иркутск (395)279-98-46
Казань (843)206-01-48
Россия +7(495)268-04-70

Калининград (4012)72-03-81
Калуга (4842)92-23-67
Кемерово (3842)65-04-62
Киров (8332)68-02-04
Коломна (4966)23-41-49
Кострома (4942)77-07-48
Краснодар (861)203-40-90
Красноярск (391)204-63-61
Курск (4712)77-13-04
Курган (3522)50-90-47
Липецк (4742)52-20-81
Магнитогорск (3519)55-03-13
Москва (495)268-04-70
Мурманск (8152)59-64-93
Набережные Челны (8552)20-53-41
Нижний Новгород (831)429-08-12
Новокузнецк (3843)20-46-81
Ноябрьск (3496)41-32-12
Новосибирск (383)227-86-73
Киргизия +996(312)-96-26-47

Омск (3812)21-46-40
Орел (4862)44-53-42
Оренбург (3532)37-68-04
Пенза (8412)22-31-16
Петрозаводск (8142)55-98-37
Псков (8112)59-10-37
Пермь (342)205-81-47
Ростов-на-Дону (863)308-18-15
Рязань (4912)46-61-64
Самара (846)206-03-16
Саранск (8342)22-96-24
Санкт-Петербург (812)309-46-40
Саратов (845)249-38-78
Севастополь (8692)22-31-93
Симферополь (3652)67-13-56
Смоленск (4812)29-41-54
Сочи (862)225-72-31
Ставрополь (8652)20-65-13
Сургут (3462)77-98-35
Казахстан +7(7172)727-132

Сыктывкар (8212)25-95-17
Тамбов (4752)50-40-97
Тверь (4822)63-31-35
Тольятти (8482)63-91-07
Томск (3822)98-41-53
Тула (4872)33-79-87
Тюмень (3452)66-21-18
Ульяновск (8422)24-23-59
Улан-Удэ (3012)59-97-51
Уфа (347)229-48-12
Хабаровск (4212)92-98-04
Чебоксары (8352)28-53-07
Челябинск (351)202-03-61
Череловец (8202)49-02-64
Чита (3022)38-34-83
Якутск (4112)23-90-97
Ярославль (4852)69-52-93