

Преобразователь частоты для подъемных механизмов P1500-L

Технические характеристики

По вопросам продаж и поддержки обращайтесь:

Алматы (7273)495-231
Ангарск (3955)60-70-56
Архангельск (8182)63-90-72
Астрахань (8512)99-46-04
Барнаул (3852)73-04-60
Белгород (4722)40-23-64
Благовещенск (4162)22-76-07
Брянск (4832)59-03-52
Владивосток (423)249-28-31
Владикавказ (8672)28-90-48
Владимир (4922)49-43-18
Волгоград (844)278-03-48
Вологда (8172)26-41-59
Воронеж (473)204-51-73
Екатеринбург (343)384-55-89
Иваново (4932)77-34-06
Ижевск (3412)26-03-58
Иркутск (395)279-98-46
Казань (843)206-01-48

Россия +7(495)268-04-70

Калининград (4012)72-03-81
Калуга (4842)92-23-67
Кемерово (3842)65-04-62
Киров (8332)68-02-04
Коломна (4966)23-41-49
Кострома (4942)77-07-48
Краснодар (861)203-40-90
Красноярск (391)204-63-61
Курск (4712)77-13-04
Курган (3522)50-90-47
Липецк (4742)52-20-81
Магнитогорск (3519)55-03-13
Москва (495)268-04-70
Мурманск (8152)59-64-93
Набережные Челны (8552)20-53-41
Нижний Новгород (831)429-08-12
Новокузнецк (3843)20-46-81
Ноябрьск (3496)41-32-12
Новосибирск (383)227-86-73

Киргизия +996(312)-96-26-47

Омск (3812)21-46-40
Орел (4862)44-53-42
Оренбург (3532)37-68-04
Пенза (8412)22-31-16
Петрозаводск (8142)55-98-37
Псков (8112)59-10-37
Пермь (342)205-81-47
Ростов-на-Дону (863)308-18-15
Рязань (4912)46-61-64
Самара (846)206-03-16
Саранск (8342)22-96-24
Санкт-Петербург (812)309-46-40
Саратов (845)249-38-78
Севастополь (8692)22-31-93
Симферополь (3652)67-13-56
Смоленск (4812)29-41-54
Сочи (862)225-72-31
Ставрополь (8652)20-65-13
Сургут (3462)77-98-35

Казахстан +7(7172)727-132

Сыктывкар (8212)25-95-17
Тамбов (4752)50-40-97
Тверь (4822)63-31-35
Тольятти (8482)63-91-07
Томск (3822)98-41-53
Тула (4872)33-79-87
Тюмень (3452)66-21-18
Ульяновск (8422)24-23-59
Улан-Удэ (3012)59-97-51
Уфа (347)229-48-12
Хабаровск (4212)92-98-04
Чебоксары (8352)28-53-07
Челябинск (351)202-03-61
Череловец (8202)49-02-64
Чита (3022)38-34-83
Якутск (4112)23-90-97
Ярославль (4852)69-52-93



PI500-L Series



Frequency inverter for lifting appliances

Product introduction

PI500-L series special Frequency inverter for Lifting is designed by Powtran Technology specially for the fields of Lifting, bridged crane, electric hoist, tower crane, construction elevator. According to frequency control technology, excellent torque control function, reliable brake control, fast stop, DC excitation, master-slave control and other technologies. Reducing the impact of starting and stopping current on mechanical system, improve the stability and comfort while the machines running. Extended the mechanical system life, greatly improve the production efficiency and save the maintenance cost of the equipment.



Product characteristics

1, Low speed, high torque, low torque pulse

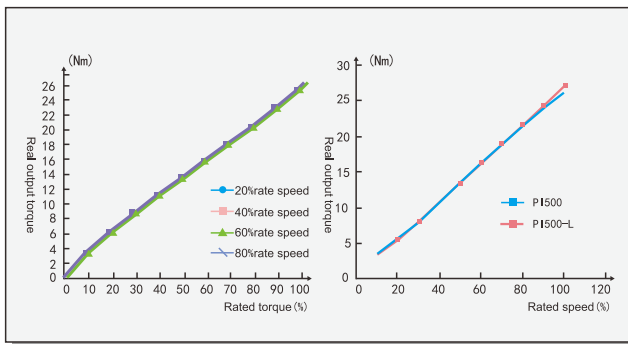

When the up-down speed is over zero, there is no need to rely on the brake action for support.

0.1Hz/150% rated torque output stably, make sure the lifting machines moving stably while starting, going up, going down.

2, Specially for Lifting, bridged crane, tower crane

PI500-L series frequency inverter is built-in with brake unit and the unique lifting braking parameters group, no need external brake unit, small shape, easy to install in cage, more adaptive to system requirements, we can set two groups of parameters for option according to users (scene).

3, Timing of special holding brake for lifting, safe and reliable

E8 parameter group has great flexibility for the adjustment of hoist function, Provide more reasonable and safe control for the hoist when starting, when the working frequency of frequency Inverter rises to the upper limit release frequency of holding brake, In order to ensure that when the brake electromagnet is released, the frequency inverter can control the lifting of heavy objects without sliding. Therefore, when the working frequency reaches the release frequency, the Inverter will start to detect the current, it can release the current within the set time, when the frequency inverter confirms that there is enough output current, it will send the command "Release", output relay 1 close, power on the holding brake, the holding brake will open, the frequency inverter rises to the required speed along the speed curve. When it stop, when the frequency inverter frequency drops to holding brake closed frequency, output relay 1 open, holding brake power off, the motor is locked by the brake shoe, the braking completed.

4, Lifting start and stop mode sequence diagram

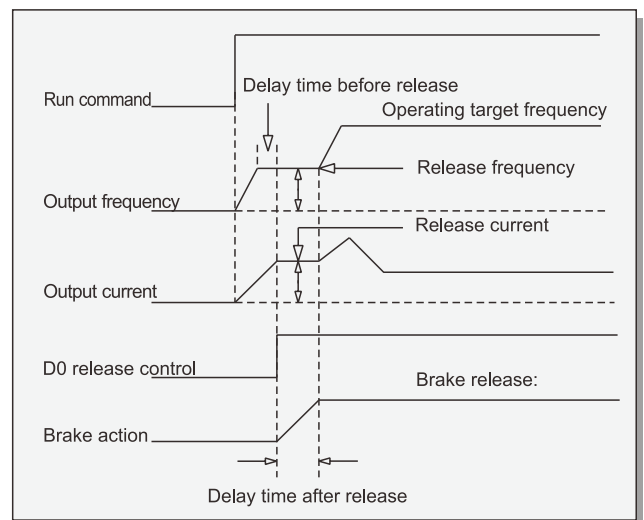

Start release mode sequence diagram

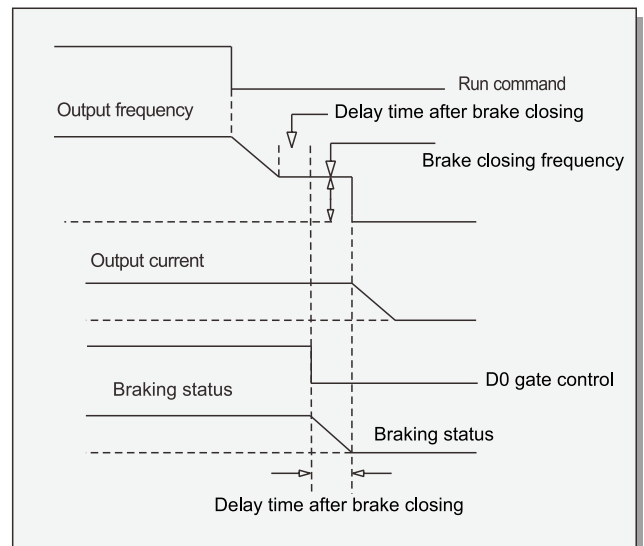

Stop brake close mode sequence diagram

5、Low voltage adaptive function: when the input voltage is unstable or momentarily reduced, the frequency inverter will automatically diagnose and output with rated torque to ensure that the hook does not slip.

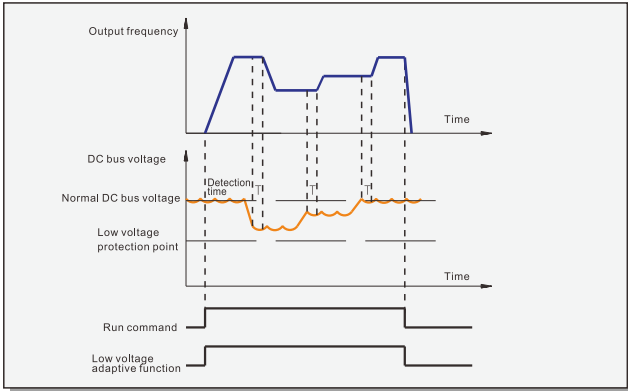

6、Stall protection function, In operation, when the actual speed is detected to be over 115% of the rated speed, the frequency inverter will immediately send out the holding brake signal to realize emergency braking (effective in closed-loop mode)

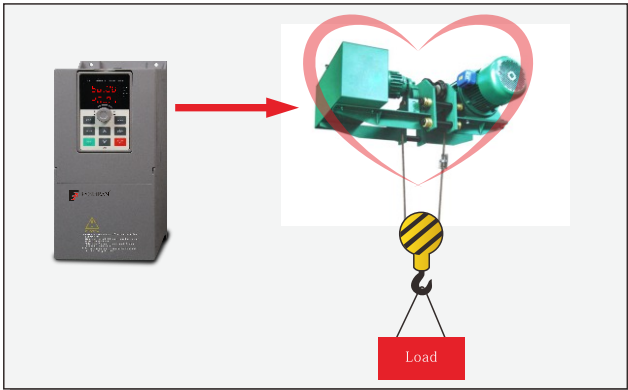

7、Support Profibus-DP, Modbus and CANopen, Profinet, Four kinds of communication protocols, so as to realize the communication connection between multiple frequency inverters, PLC and HMI.

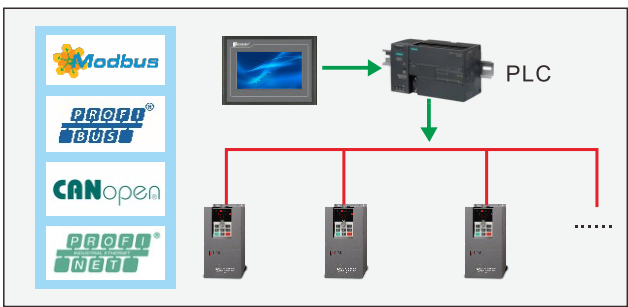

8、Transfer high speed function, according to the weight of the crane, realize automatic lifting speed when light load cargo and empty hook, and effectively improve the working efficiency of the crane.

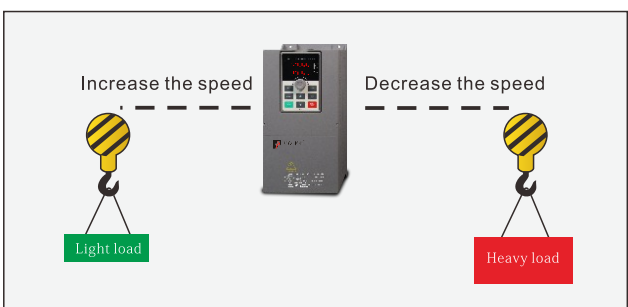

9、Zero speed torque holding function. When the brake is closed, the motor outputs enough torque to keep the load static, so as to prevent the brake from long mechanical delay.

10、IoT expansion port: Realize satellite position and remote monitoring of the internet of things to facilitate the establishment of an intelligent information management system (under development)

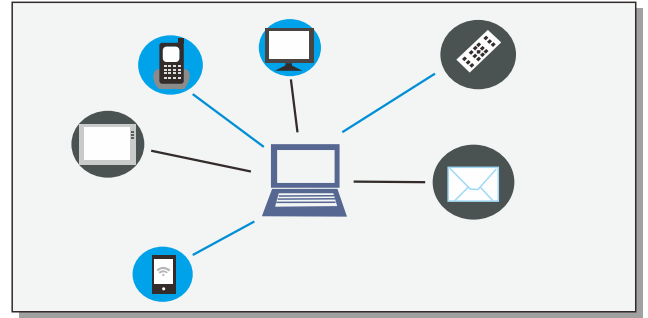

11、Zero servo hover function (closed-loop mode): in zero speed state, keep the brake open, and keep the elevator hook hovering in the air stationary.

12、Copy function of function parameters. After debugging, the inverter parameters can be copied to other inverters of the same application through keyboard, so as to simplify the debugging work.

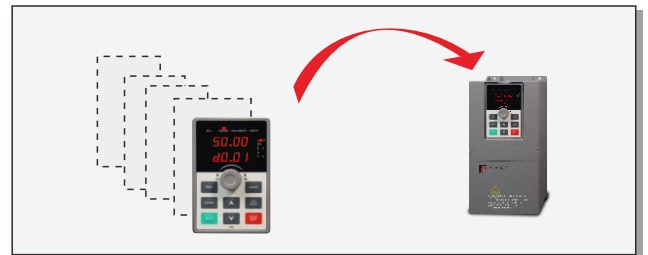

13、Built in lifting synchronization, crane deviation correction, trolley synchronization, grab control, anti swing control, tower crane, lifting and other special functions

14、Motor fan control function: output immediately during operation, stop output and delay shutdown

Special control for lifting (lifting)

1、Master slave synchronous control function: When the double lifting mechanism lifts a heavy object at the same time, the master-slave speed synchronous control function can ensure the synchronous lifting of the two lifting mechanisms and ensure safety.

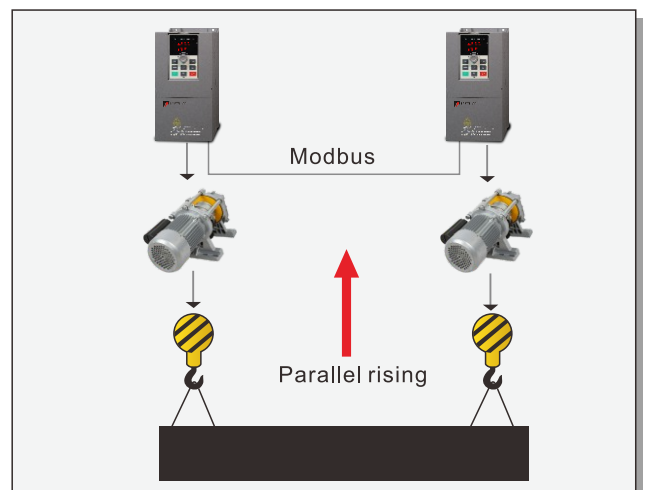

2, Rope detection function Prevent unsafe operation caused by erroneous operation of light load and high speed function when crane rope is slack

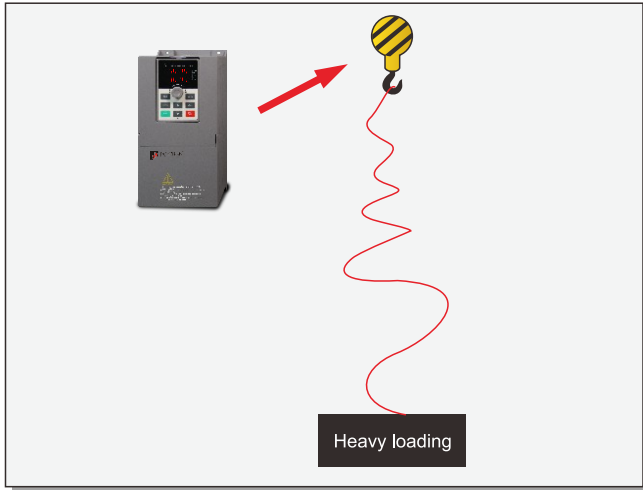

3, Real-time correction control (in closed-loop mode): suitable for applications with large spans, the master and slave use real-time position correction to meet the synchronous control of the position of the cart (suitable for driving, gantry crane walking mechanism)

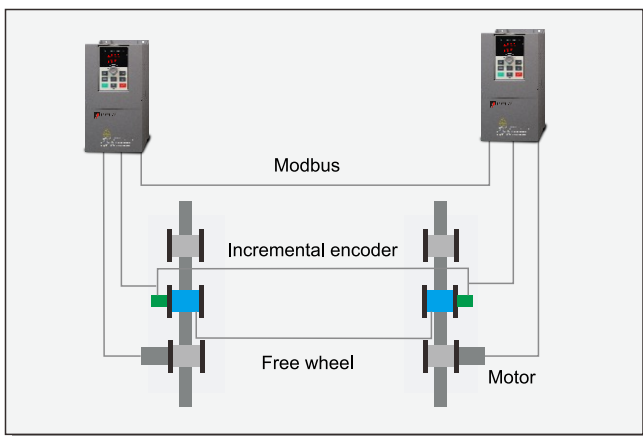

4, Torque verification function: Before the brake is released, the inverter checks whether the torque output of the motor is normal, and then releases the brake to prevent the load from falling.

5, Torque holding function: When the brake is closed, the motor continues to output enough torque to keep the load stationary to prevent the load from falling.

6, Full torque monitoring function: Torque monitoring is performed during operation. When abnormal torque output is detected, the output is immediately blocked to achieve emergency shutdown.

7, Anti-skid hook protection function: In closed loop mode, when the inverter is powered on and in standby mode, this function is immediately activated when the motor is detected to rotate, and the inverter is locked at zero speed output, which provides maximum safety for system operation

8, Electronic anti-sway function: through dynamic adjustment of the speed and acceleration / deceleration time control of the small and large cars in operation, reduce the amplitude of the load swinging out of thin air, so that when the speed is stable or stopped, the goal is to achieve a small or almost constant load swing. Improve work efficiency

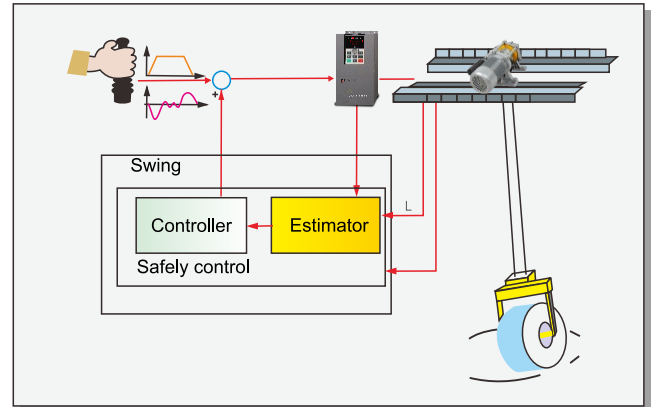

Tower crane dedicated control (slewing)

- 1, Flexible torque control, "flexible belt rigid" jogging is strong and powerful, fast response, stable boom does not rebound
- 2, Swing control application macros: eddy current motor control mode, ordinary motor torque control mode, hydraulic coupling control mode
- 3, Adapt to various types of motor control: 1, rigid connection of eddy current motor 2, soft connection of hydraulic coupling 3, rigid connection of torque motor
- 4, Low-speed operation, smooth gear shifting, smooth and smooth boom, no stall

Special control for electric hoist

- 1, Electric hoist control: application macro for cone motor (under development)

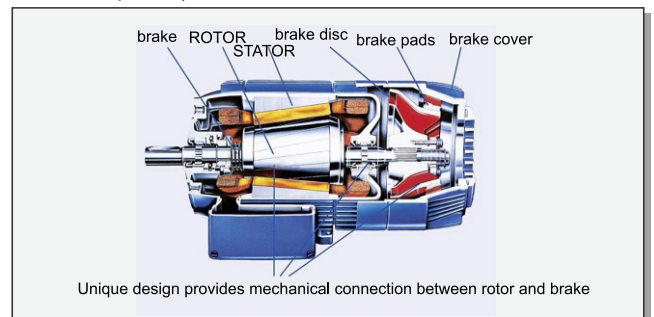

- 2, Remote control device expansion port: easy to expand external remote control devices



- 3, Can be customized for customers, develop two-in-one or three-in-one transfer

Installation size

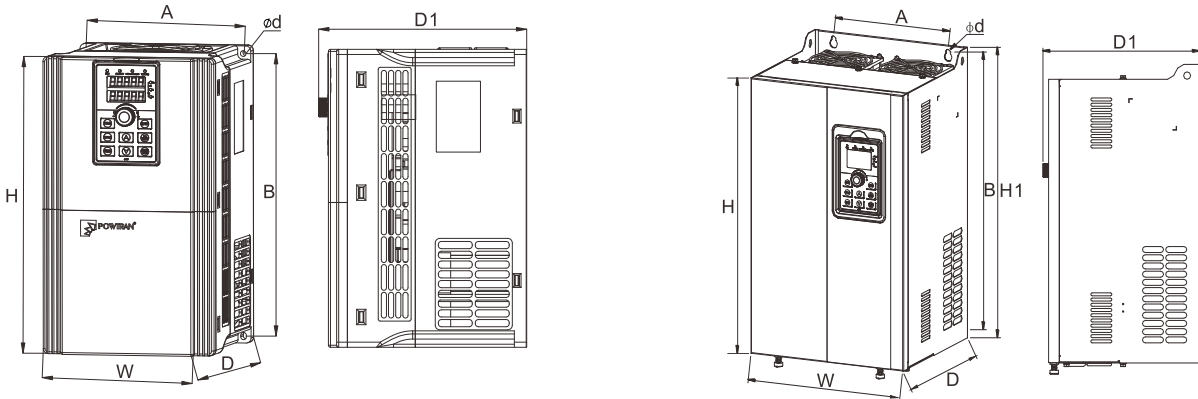

Model	Voltage (V)	Power (kW)	Input current (A)	Output current (A)	Dimensions(mm)					Installation dimensions (mm)			N.w. (kg)
					H	H1	W	D	D1	A	B	d	
PI500-L 0R7G3	3PH 380V (-15%) ~ 440V (+10%)	0.75	4.3	2.5	163	185	90	146	154	65	174	5	1.6
PI500-L 1R5G3		1.5	5.0	3.8									
PI500-L 2R2G3		2.2	5.8	5.1									
PI500-L 004G3		4.0	10.5	9	163	185	90	166	174	65	174	5	1.9
PI500-L 5R5G3		5.5	14.6	13									
PI500-L 7R5G3		7.5	20.5	17									
PI500-L 011G3		11	26	25	280	300	190	190	198	140	285	6	7.2
PI500-L 015G3		15	35	32									
PI500-L 018G3		18.5	38.5	37									
PI500-L 022G3		22	46.5	45	330	350	210	190	198	150	335	6	9.5
PI500-L 030G3 (B)		30	62	60									
PI500-L 037G3 (B)		37	76	75									
PI500-L 045G3 (B)		45	91	90	380	400	240 (280)	215	223	180	385	7	14
PI500-L 055G3 (B)		55	112	110									
PI500-L 075G3 (B)		75	157	150									
					500	520	300 (340)	275	283	220	500	10	47

* Each power section is equipped with a built-in braking unit as standard. The G dimension of the model G3B is larger than that of standard products. Please pay attention to the installation dimensions when designing the cabinet. 30G3-75G3 requires an external braking unit

application

PI500-L special inverter for hoisting and lifting, with intelligent, lightweight, modular, tailor-made structure design subverts the traditional electrical control module, and provides customers with a complete set of electrical control system solutions. Has been quickly recognized and accepted by our customers, widely used in construction machinery, construction elevators, portal cranes, electric hoists, tower cranes

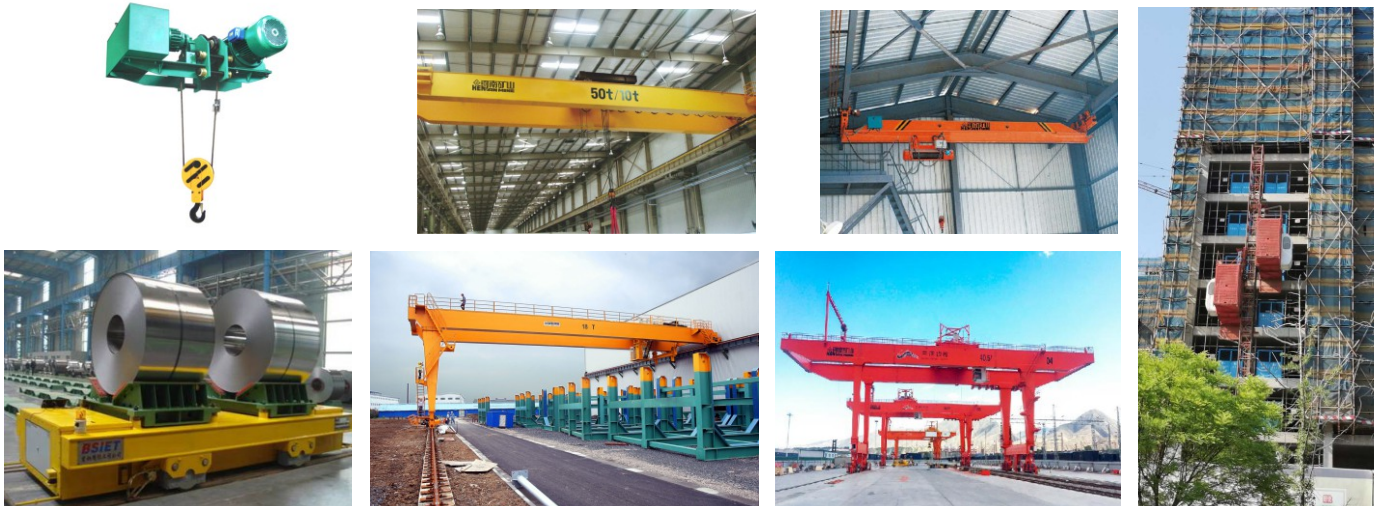

Service Network:

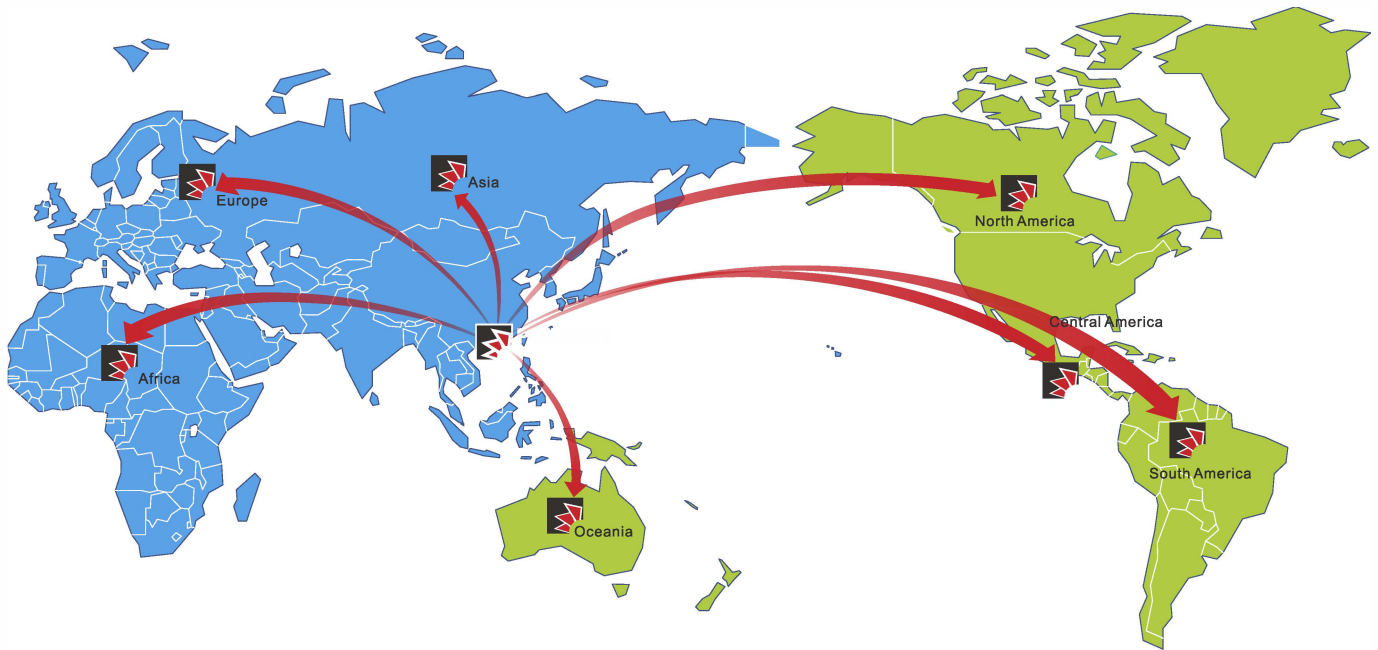

Powtran technology

A manufacturer of motor control intelligent products and devices based on motor design.



По вопросам продаж и поддержки обращайтесь:

Алматы (7273)495-231
Ангарск (3955)60-70-56
Архангельск (8182)63-90-72
Астрахань (8512)99-46-04
Барнаул (3852)73-04-60
Белгород (4722)40-23-64
Благовещенск (4162)22-76-07
Брянск (4832)59-03-52
Владивосток (423)249-28-31
Владикавказ (8672)28-90-48
Владимир (4922)49-43-18
Волгоград (844)278-03-48
Вологда (8172)26-41-59
Воронеж (473)204-51-73
Екатеринбург (343)384-55-89
Иваново (4932)77-34-06
Ижевск (3412)26-03-58
Иркутск (395)279-98-46
Казань (843)206-01-48

Калининград (4012)72-03-81
Калуга (4842)92-23-67
Кемерово (3842)65-04-62
Киров (8332)68-02-04
Коломна (4966)23-41-49
Кострома (4942)77-07-48
Краснодар (861)203-40-90
Красноярск (391)204-63-61
Курск (4712)77-13-04
Курган (3522)50-90-47
Липецк (4742)52-20-81
Магнитогорск (3519)55-03-13
Москва (495)268-04-70
Мурманск (8152)59-64-93
Набережные Челны (8552)20-53-41
Нижний Новгород (831)429-08-12
Новокузнецк (3843)20-46-81
Ноябрьск (3496)41-32-12
Новосибирск (383)227-86-73

Омск (3812)21-46-40
Орел (4862)44-53-42
Оренбург (3532)37-68-04
Пенза (8412)22-31-16
Петрозаводск (8142)55-98-37
Псков (8112)59-10-37
Пермь (342)205-81-47
Ростов-на-Дону (863)308-18-15
Рязань (4912)46-61-64
Самара (846)206-03-16
Саранск (8342)22-96-24
Санкт-Петербург (812)309-46-40
Саратов (845)249-38-78
Севастополь (8692)22-31-93
Симферополь (3652)67-13-56
Смоленск (4812)29-41-54
Сочи (862)225-72-31
Ставрополь (8652)20-65-13
Сургут (3462)77-98-35

Сыктывкар (8212)25-95-17
Тамбов (4752)50-40-97
Тверь (4822)63-31-35
Тольятти (8482)63-91-07
Томск (3822)98-41-53
Тула (4872)33-79-87
Тюмень (3452)66-21-18
Ульяновск (8422)24-23-59
Улан-Удэ (3012)59-97-51
Уфа (347)229-48-12
Хабаровск (4212)92-98-04
Чебоксары (8352)28-53-07
Челябинск (351)202-03-61
Череловец (8202)49-02-64
Чита (3022)38-34-83
Якутск (4112)23-90-97
Ярославль (4852)69-52-93

Россия +7(495)268-04-70

Киргизия +996(312)-96-26-47

Казахстан +7(7172)727-132

<https://powtran.nt-rt.ru> || prw@nt-rt.ru